



MA 1245

MA 1246

Teileliste

Parts list

Lista de piezas

零件表

This manual applies to all machines of the mentioned type from the following serial number onward: # 100011 →

本零件表对从下列序列号起的机器有效:

4153-1-1245-4-2  
Taicang 2012-05  
© Tribonia Intl.

Alle Informationen und Abbildungen waren zum Zeitpunkt der Druckgebung auf dem neusten Stand.

Technische Änderungen vorbehalten!

Der Nachdruck, die Vervielfältigung sowie die Übersetzung - auch auszugsweise - aus Mauser Spezial-Teilleisten ist nur mit unserer vorherigen Zustimmung und mit der Quellenangabe gestattet.

At the time of printing, all information and illustrations contained in this document were up to date.

Subject to alteration!

The reprinting, copying or translation of Mauser Spezial Parts lists whether in whole or in part, is only permitted with our previous permission and with written reference to the source.

Todas las informaciones e ilustraciones de este manual estaban al día en el momento de entregarse para su impresión.

¡ Salvo modificaciones técnicas!

La reimpresión, reproducción y traducción - aunque sólo sea parcial - de las listas de piezas Mauser Spezial sólo está permitida con nuestro permiso previo e indicando la fuente.

所有信息和图片在付印时都是最新的。

保留技术更改的权力！

全部或部分翻印、复制以及翻译 Mauser Spezial 零件表必须事先经由我们同意并且注明来源。

## **Mauser Spezial**

Pfaff Industrial (Taicang) Co., Ltd.  
No. 105 Shanghai East Road  
A20 Foreign Industrial Park  
215400 Taicang, Jiangsu  
People's Republic of China

	<b>Seite</b> Page Página 页
<b>0</b> <b>Wichtiger Hinweis</b> .....	<b>5</b>
Important note	
Observación importante	
重要提示	
<b>1</b> <b>Vorwort</b> .....	<b>6</b>
Foreword	
Notas preliminares	
前言	
<b>2</b> <b>Erläuterungen der Schlüsselzeichen</b> .....	<b>7</b>
Explanation of key markings	
Explicaciones de los signos clave	
标记说明	
<b>3</b> <b>Basismaschine</b>	
Basic machine	
Máquina básicas	
基础机器	
<b>3.01</b> <b>Gehäuseteile</b> .....	<b>9</b>
Housing sections	
Piezas del cárter	
机身零件	
<b>3.02</b> <b>Kopfteile</b> .....	<b>10</b>
Needle head parts	
Piezas de la cabeza	
机头零件	
<b>3.03</b> <b>Armteile</b> .....	<b>14</b>
Arm parts	
Piezas del brazo	
机臂零件	
<b>3.04</b> <b>Grundplattenteile</b> .....	<b>20</b>
Bedplate parts	
Piezas del cárter	
底板零件	
<b>4</b> <b>Abweichende Teile der MA 1246</b> .....	<b>27</b>
Different parts for MA 1246	
Piezas de la MA 1246 que son diferentes	
MA 1246    中有差别的零件	
<b>5</b> <b>Nähfuß heben über Pedal (-910/01)</b> .....	<b>32</b>
Raiser presser foot via the pedal (-910/01)	
Elevación del prensatelas mediante pedal (-910/01)	
用踏板抬起压脚 (-910/01)	
<b>6</b> <b>Garnrollenständer</b> .....	<b>33</b>
Reel stands	
Portacarretes	
线轴支架	

	Seite Page Página 页
<b>7</b> <b>Einstellehren</b> .....	<b>34</b>
Adjustment gauges Calibres de ajuste 设置量规	
<b>8</b> <b>Teile zur Tischplatte</b> .....	<b>34</b>
Parts for table top Piezas para el tablero 用于台板的零件	
<b>9</b> <b>Keilriemen</b> .....	<b>35</b>
V-belt Correa trapezoidal 三角皮带	
<b>10</b> <b>Knielüfterteile</b> .....	<b>35</b>
Knee lifter parts Piezas del alzaprensatelas por rodillera 膝松线器零件	
<b>11</b> <b>Schmiermittel-Übersicht</b> .....	<b>36</b>
Overview of lubricants Tabla de lubricantes 润滑剂一览	
<b>12</b> <b>Index (Teilenummern / Seitenzahlen)</b> .....	<b>37</b>
Index (part numbers / page numbers) Index (números de pieza / números de página) 注脚(零件号/页号)	
<b>13</b> <b>Unterklassen-Ausstattung</b> Subclass parts Composición de las subclases 子机型-设备	
<b>13.01</b> <b>Nähwerkzeuge (MA 1245)</b> .....	<b>42</b>
Gauge parts (MA 1245) Organos de costura (MA 1245) 缝纫工具 (MA 1245)	
<b>13.02</b> <b>Nähwerkzeuge (MA 1246)</b> .....	<b>44</b>
Gauge parts (MA 1246) Organos de costura (MA 1246) 缝纫工具 (MA 1246)	

### Achtung!



Wir machen ausdrücklich darauf aufmerksam, daß Ersatz- und Zubehörteile, die nicht von uns geliefert werden, auch nicht von uns geprüft und freigegeben sind. Der Einbau und / oder die Verwendung solcher Produkte kann daher u. Umständen konstruktiv vorgegebene Eigenschaften Ihrer Maschine negativ verändern. Für Schäden, die durch die Verwendung von Nicht-Originalteilen entstehen, übernehmen wir keine Haftung!

### Caution!



We warn you expressively that spare parts and accessories that are not supplied by us are not tested and released by us. Fitting or using these products may therefore have negative influences on features that depend on the machine design. We are not liable for any damage caused by the use of non-MA parts!

### ¡Atención!



Se hace observar que en el caso de piezas de recambio y accesorios que no hayan sido suministrados por nosotros, quiere decir que non han sido sometidas por nuestra parte a un control y que no se les ha dado el visto bueno. Por esta razón, el montaje y/o empleo de tales productos puede repercutir negativamente en las características previstas en su máquina. ¡Para los daños que eventualmente pudiesen presentarse al utilizar piezas no originales, no asumimos ninguna garantía!

### 注意!



我们必须明确指出，所有不是由我们供货的备件和附件都未经我们检查，也没有被我们批准使用。装入和/或使用这些产品可能在一定的情况下会对机器的设计特性造成负面改变。对由于使用非原装件所造成的损失，我们不负任何责任！

- Die Seriennummer der Maschine, für die diese Teileliste Gültigkeit hat, ist auf der Titelseite aufgeführt.
  - Alle Teile sind so abgebildet, wie sie in der Maschine funktionsmäßig zusammengehören.
  - Gestrichelt dargestellte Teile zeigen angrenzende Teile aus anderen Funktionsgruppen.
  - Im oberen Teil der Bildseiten befindet sich eine Gesamtansicht der Maschine .
  - Der Einbauort der dargestellten Teile wird durch eine gerasterte Fläche gekennzeichnet.
  - Einrahmungen auf den Bildseiten zeigen, aus welchen Einzelteilen sich die Gruppenteile zusammensetzen.
  - Die auf den Bildseiten verwendeten Schlüsselzeichen (  ;  2 ;  3 usw.) sind im Kapitel "Erläuterungen der Schlüsselzeichen" aufgelistet.
- 
- The serial number of the machine to which this parts list applies is indicated on the cover page.
  - All parts are illustrated in function groups with the parts which they function together with in the machine.
  - Parts illustrated with broken lines are parts from other function groups which border on the illustrated function group.
  - The above section of the page of illustrations contains a total view of the machine. The place for the installation of the parts pictured here is marked by the grid.
  - The framed-in sections on the illustration pages show the individual parts comprising a group.
  - The key markings used on the illustrated pages (  ;  2 ;  3 etc.) are listed in the chapter "Explanation of key markings".
- 
- El número de serie de la máquina para la cual tiene validez esta lista de piezas va indicado en la página de título.
  - Todas las piezas están ilustradas tal como aparecen en la máquina para su funcionamiento.
  - Las piezas representadas con rayitas muestran piezas colindantes de otros grupos de funciones.
  - En la parte superior de las páginas ilustradas se puede ver una vista en conjunto de la máquina.
  - El lugar de montaje de la pieza representada va caracterizada mediante una superficie reticulada.
  - Los recuadros en las páginas ilustradas indican las piezas individuales de que se componen los grupos.
  - Los signos clave (  ;  2 ;  3 etc.) empleados en las páginas con ilustraciones van listados en el capítulo "Explicaciones de los signos clave".
- 
- 适用于本零件表的机器系列号列在首页上。
  - 所有的零件都按照其在机器中的功能情况合在一起表达。
  - 用虚线表示的零件为相邻功能组中的零件。
  - 图的上部为机器全景。
  - 所示零件的安装部位用影格面表示。
  - 页上的框表示这套组件都由哪些零件所组成。
  - 图页上所使用的标记 (  ;  2 ;  3 等) 列表在“标记说明”中。

- Unterklassenabhängig, Teilenummer siehe Unterklassen-Ausstattung.**  
Subclas-dependent, for part number see subclass parts listing.  
Dependientes de la subclase, para el número de pieza véase "Dotación de subclases".  
取决于子机型，零件号见子机型设备。
- C** **Maschinen-Ausstattung für mittelschwere Materialien.**  
Model C for sewing medium-heavy materials.  
Tipo C para materiales semipesados.  
用于中偏厚料的机器设备。
- N** **Stichlänge 6,0 mm.**  
Stitch lenght 6.0 mm.  
Largo de puntada 6,0 mm  
针距6.0 mm。
- N8** **Stichlänge 8,0 mm.**  
Stitch lenght 8.0 mm.  
Largo de puntada 8,0 mm  
针距8.0 mm。
- P** **Teile zum Hüpftransport.**  
Components of four-motion drop feed.  
Piezas del transportador inferior a cuatro tiempos.  
下送料装置中的零件
- 3** **Geklebt**  
Part cemented  
Pieza pegada  
被粘住。
- 5** **Nähmuster bzw. Material einsenden.**  
Submit sewing sample or material.  
Enviense muestras de costura.  
投寄缝纫样品及缝料。
- 6** **Nadeldicke und Spitzenform bei Bestellung angeben.**  
Needle size and style of point to be stated on order.  
Grosor de aguja y forma de la punta, indíquese en los pedidos.  
在订货时给出针厚和针尖型式。
- 27/2** **Eingeklammerte Zahl = Dicke in mm.**  
Number in brackets = thickness in mm.  
Cifra entre paréntesis = espesor en mm.  
括起的数字 = 厚度 (单位 mm)
- 27/5** **Eingeklammerte Zahl = Länge in mm.**  
Number in brackets = length in mm.  
Cifra entre paréntesis = largura en mm.  
被括起的数字=长度，单位mm。
- 35/4** **Bei Montage bohren und verstiften.**  
To be drilled and pinned after assembly.  
Debera bacerse un taladro y colocarse un pasador antes del montaje.  
在安装时钻孔和加定位销
- 40/1** **Füllen mit 28-011 201-44; Bestellnummer siehe Seite 36.**  
Top up with 28-011 201-44; for part number see page 36.  
Rellene con 28-011 201-44; para el número de pedido véase la página 36.  
注油用 28-011 201-44; 订货号见 36页。

- 40/2**      **Tränken mit 28-011 201-44; Bestellnummer siehe Seite 36.**  
Grease with 28-011 201-44; for part number see page 36.  
Engrase con grasa 28-011 201-44; para el número de pedido véase la página 36.  
浸油用 28-011 201-44; 订货号见 36 页。
- 40/3**      **Fetten mit 28-011 202-47; Bestellnummer siehe Seite 36.**  
Grease with 28-011 202-47; for part number see page 36.  
Engrase con grasa 28-011 202-47; para el número de pedido véase la página 36.  
上脂用 28-011 202-47; 订货号见 36 页。
- 40/4**      **Fetten mit 28-011 202-43; Bestellnummer siehe Seite 36.**  
Grease with 28-011 202-43; for part number see page 36.  
Engrase con grasa 28-011 202-43; para el número de pedido véase la página 36.  
上脂用 28-011 202-43; 订货号见 36 页。
- 40/13**      **Fetten mit 28-011 202-05; Bestellnummer siehe Seite 36.**  
Grease with 28-011 202-05; for part number see page 36.  
Engrase con grasa 28-011 202-05; para el número de pedido véase la página 36.  
上脂用 28-011 202-05; 订货号见 36 页。
- 90/47**      **Nr. 91-141 572-12 mitbestellen.**  
Include No. 91-141 572-12 in your order.  
Pidase juntamente el N° 91-141 572-12.  
随同订购编号 91-141 572-12.



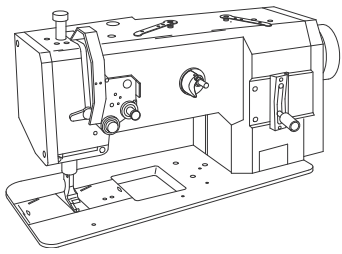

Gehäuseteile  
Housing sections  
Piezas del cárter  
机身零件

MA1245

3.01

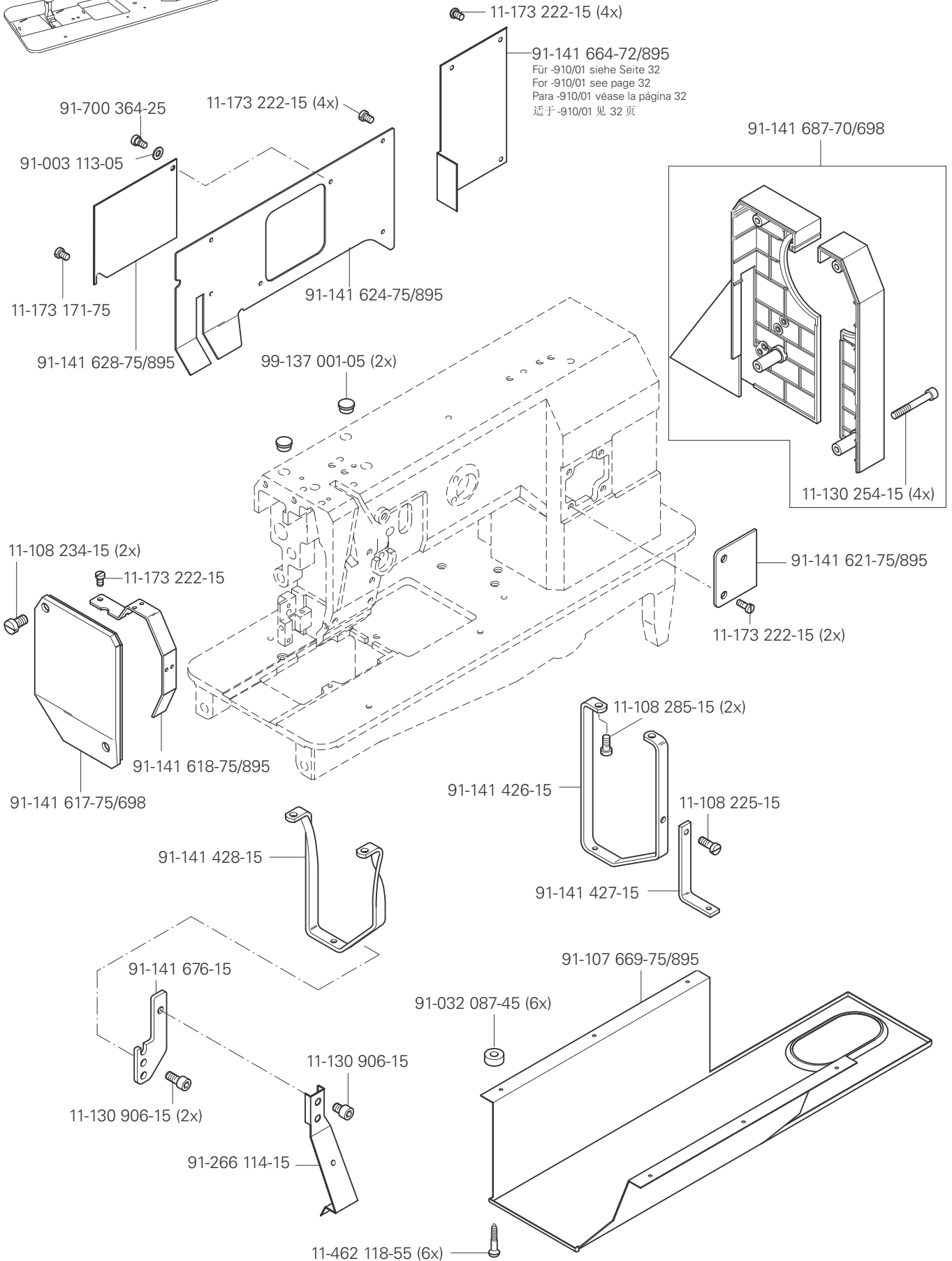

☐ siehe Kapitel 2 Erläuterung der Schlüsselzeichen  
see chapter 2 Explanation of key markings  
véase el Cap. 2 Explicaciones de los signos clave  
见第 2 章 符号说明

# 3.02

## Kopfteile Needle head parts Piezas de la cabeza 机头零件

MA 1245

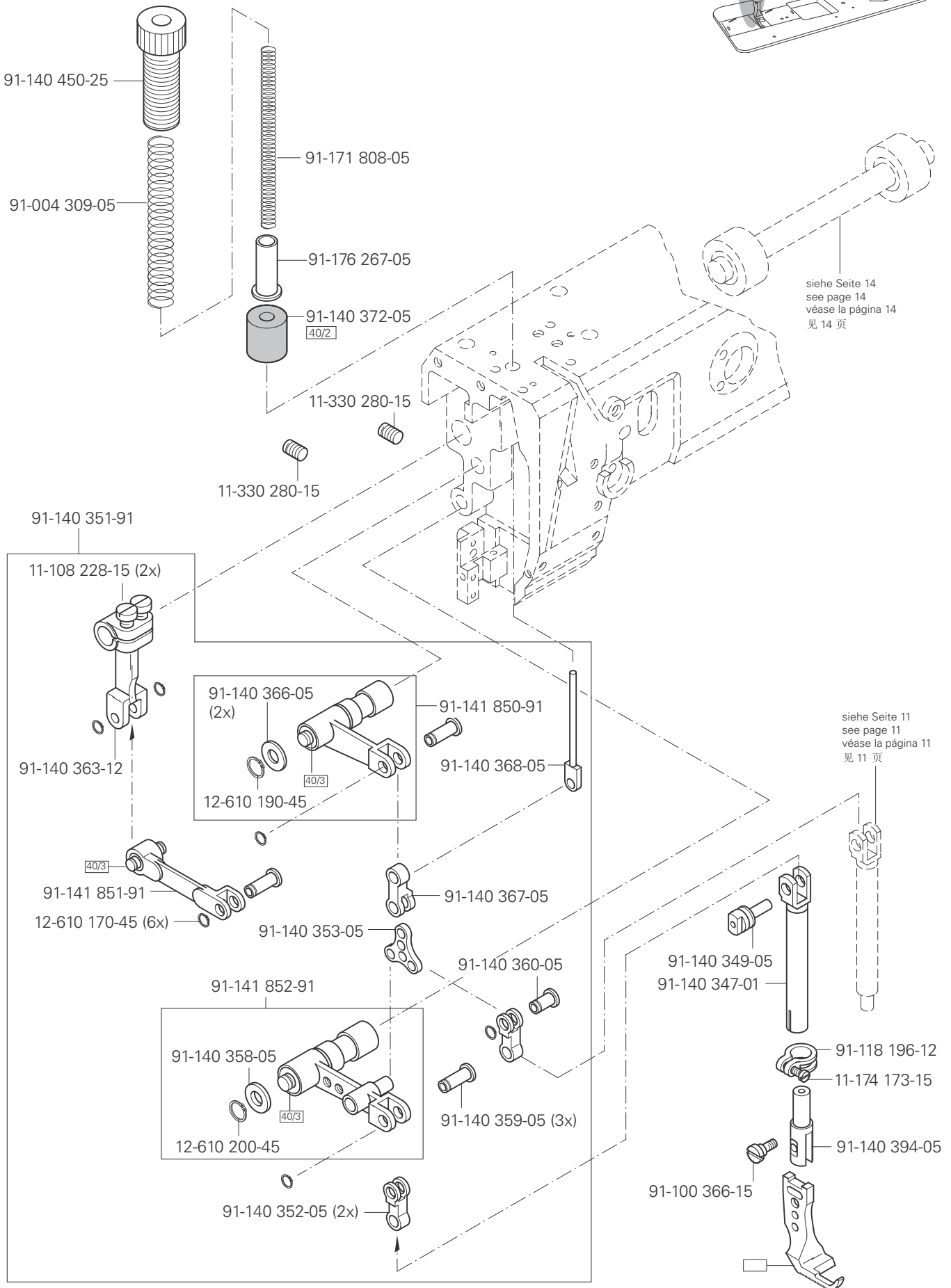
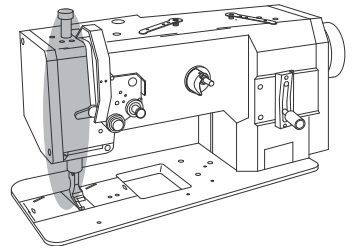

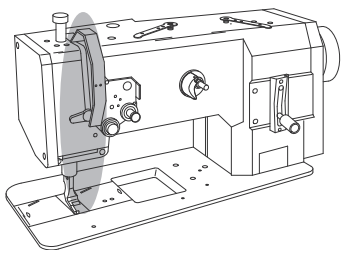

Kopfteile  
Needle head parts  
Piezas de la cabeza  
机头零件

MA 1245

3.02

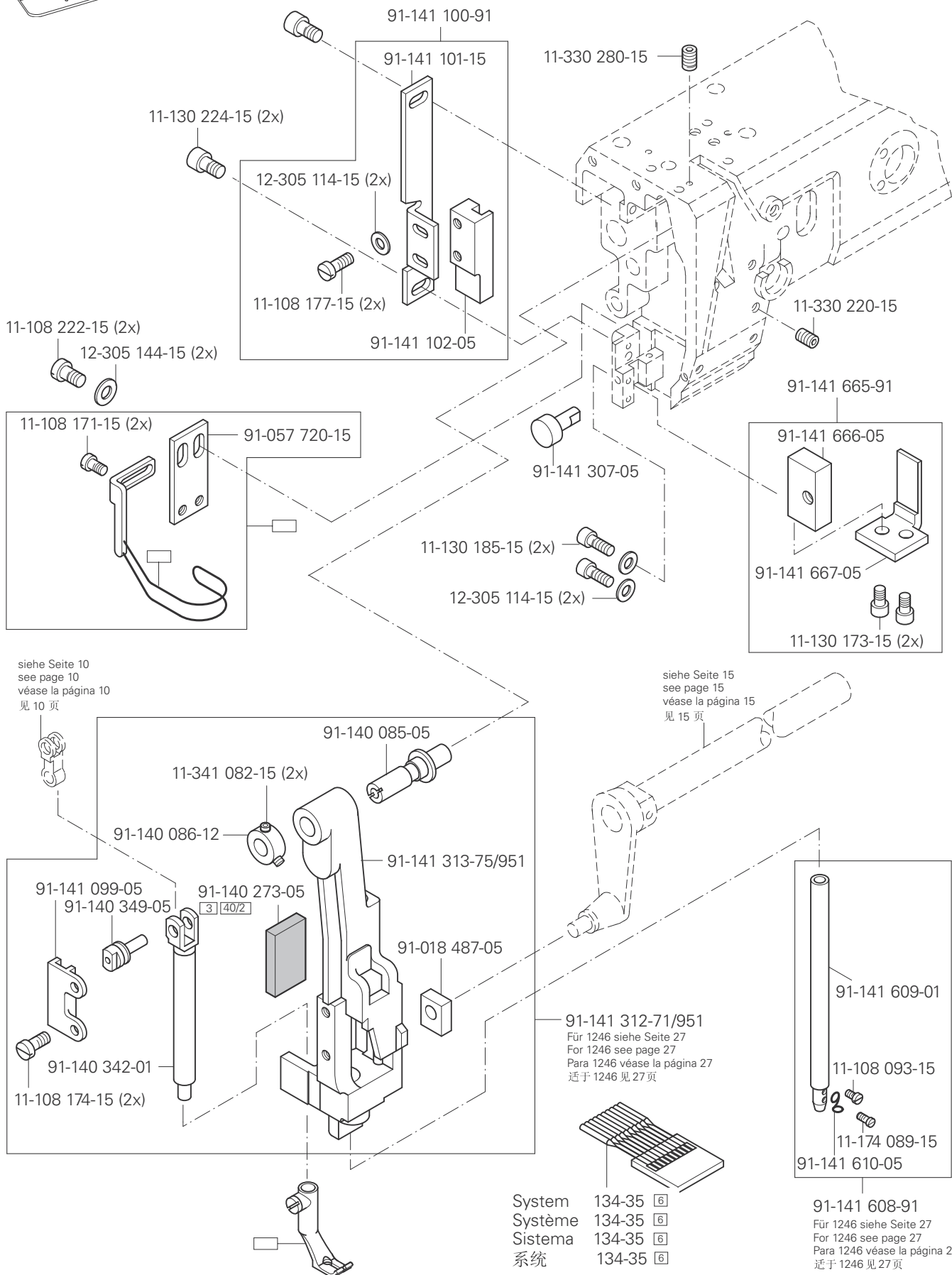

☐ siehe Kapitel 2 Erläuterung der Schlüsselzeichen  
see chapter 2 Explanation of key markings  
véase el Cap. 2 Explicaciones de los signos clave  
见第 2 章 符号说明

# 3.02

Kopfteile  
Needle head parts  
Piezas de la cabeza  
机头零件

MA 1245

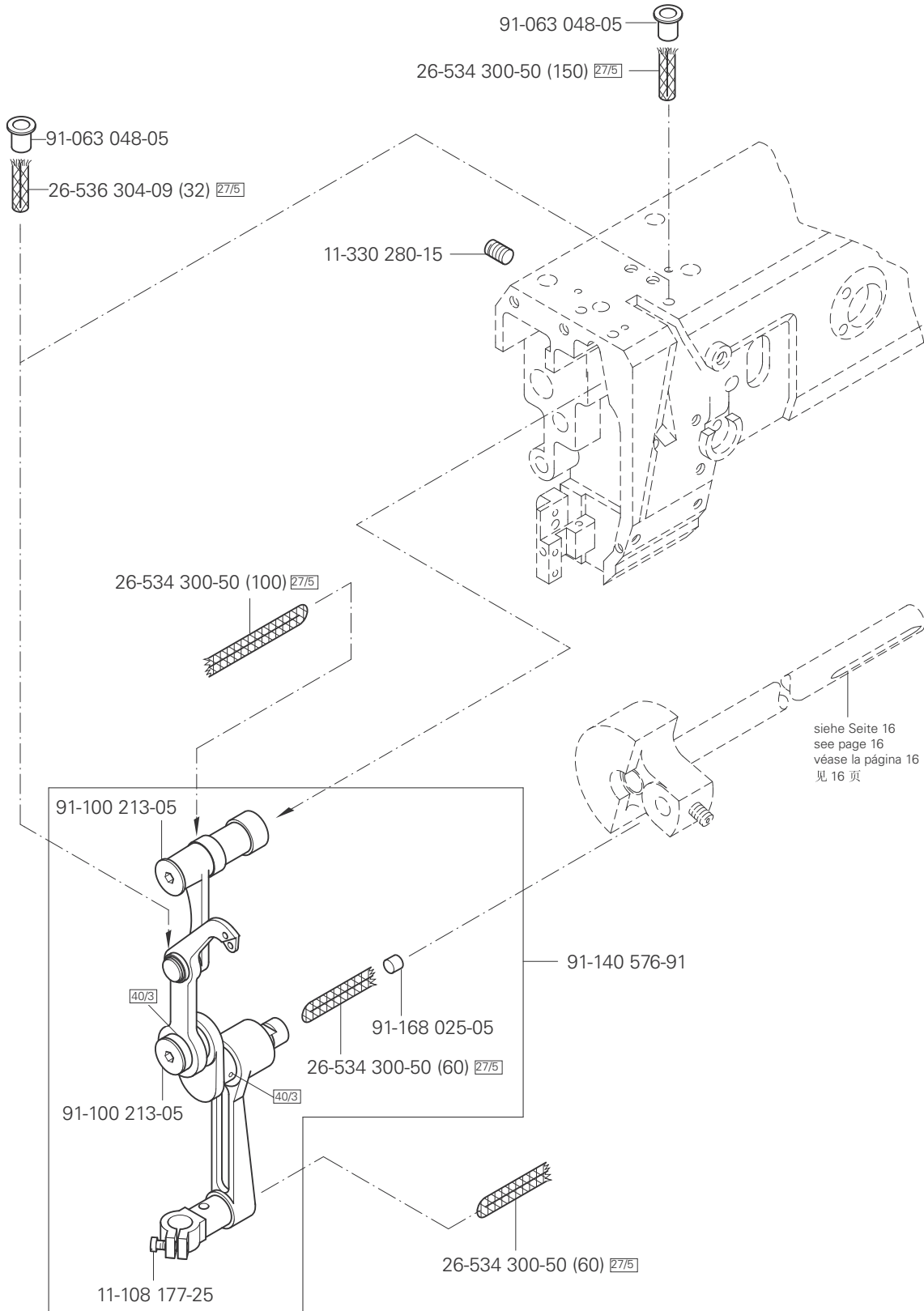
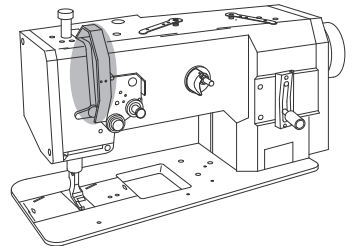

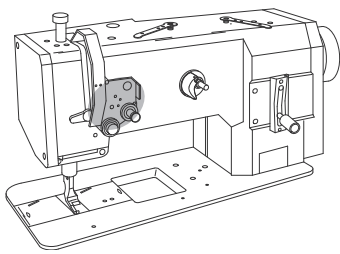

Kopfteile  
Needle head parts  
Piezas de la cabeza  
机头零件

MA 1245

3.02

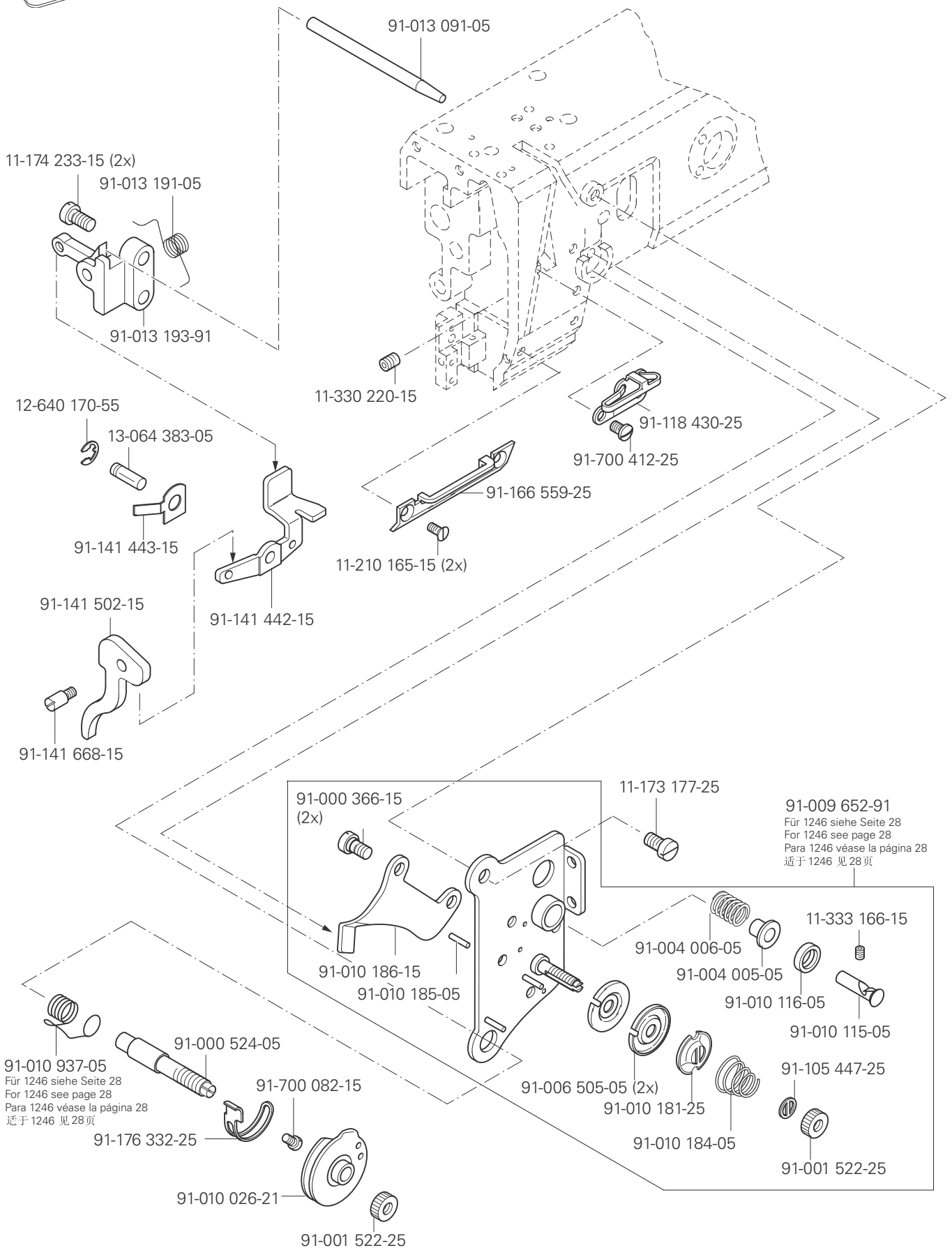

☐ siehe Kapitel 2 Erläuterung der Schlüsselzeichen  
see chapter 2 Explanation of key markings  
véase el Cap. 2 Explicaciones de los signos clave  
见第 2 章 说明

# 3.03

Armteile  
 Arm parts  
 Piezas del brazo  
 机臂零件

MA 1245

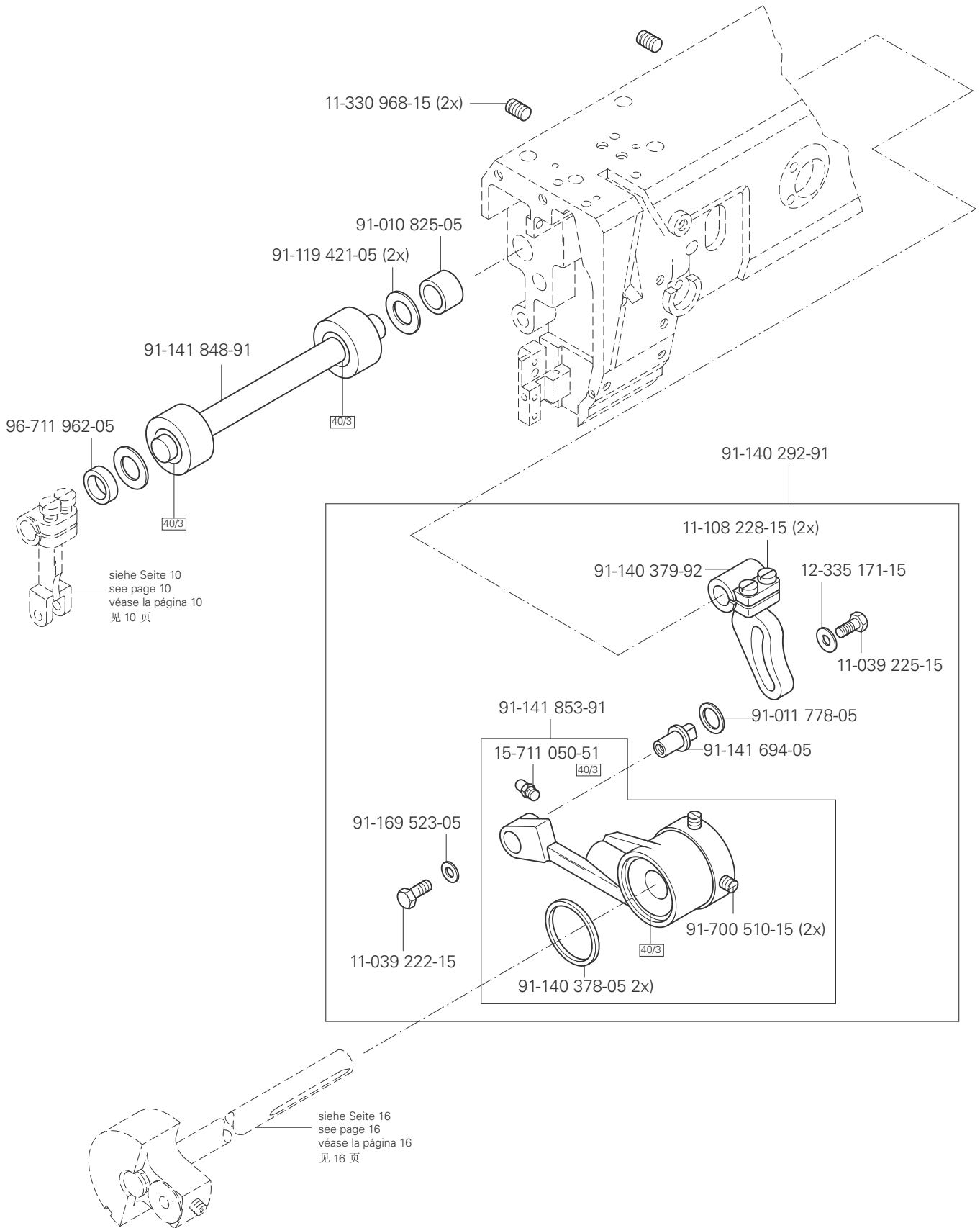
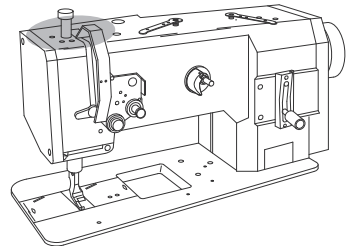

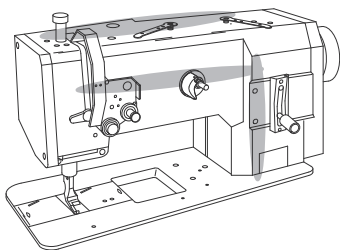

Armteile  
 Arm parts  
 Piezas del brazo  
 机臂零件

MA 1245

3.03

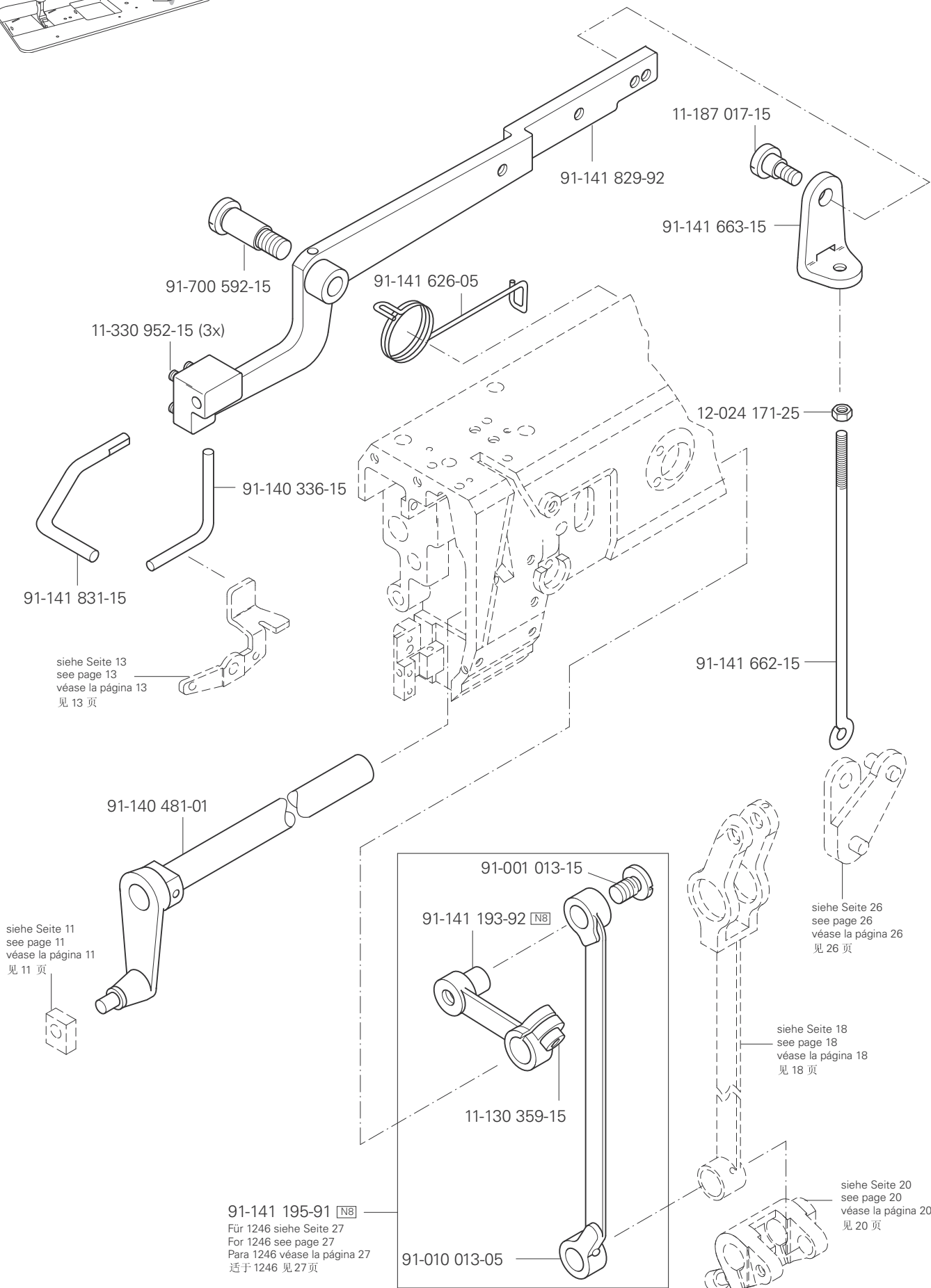

☐ siehe Kapitel 2 Erläuterung der Schlüsselzeichen  
 see chapter 2 Explanation of key markings  
 véase el Cap. 2 Explicaciones de los signos clave  
 见第 2 章 说明



# 3.03

## Armteile Arm parts Piezas del brazo 机臂零件

MA 1245

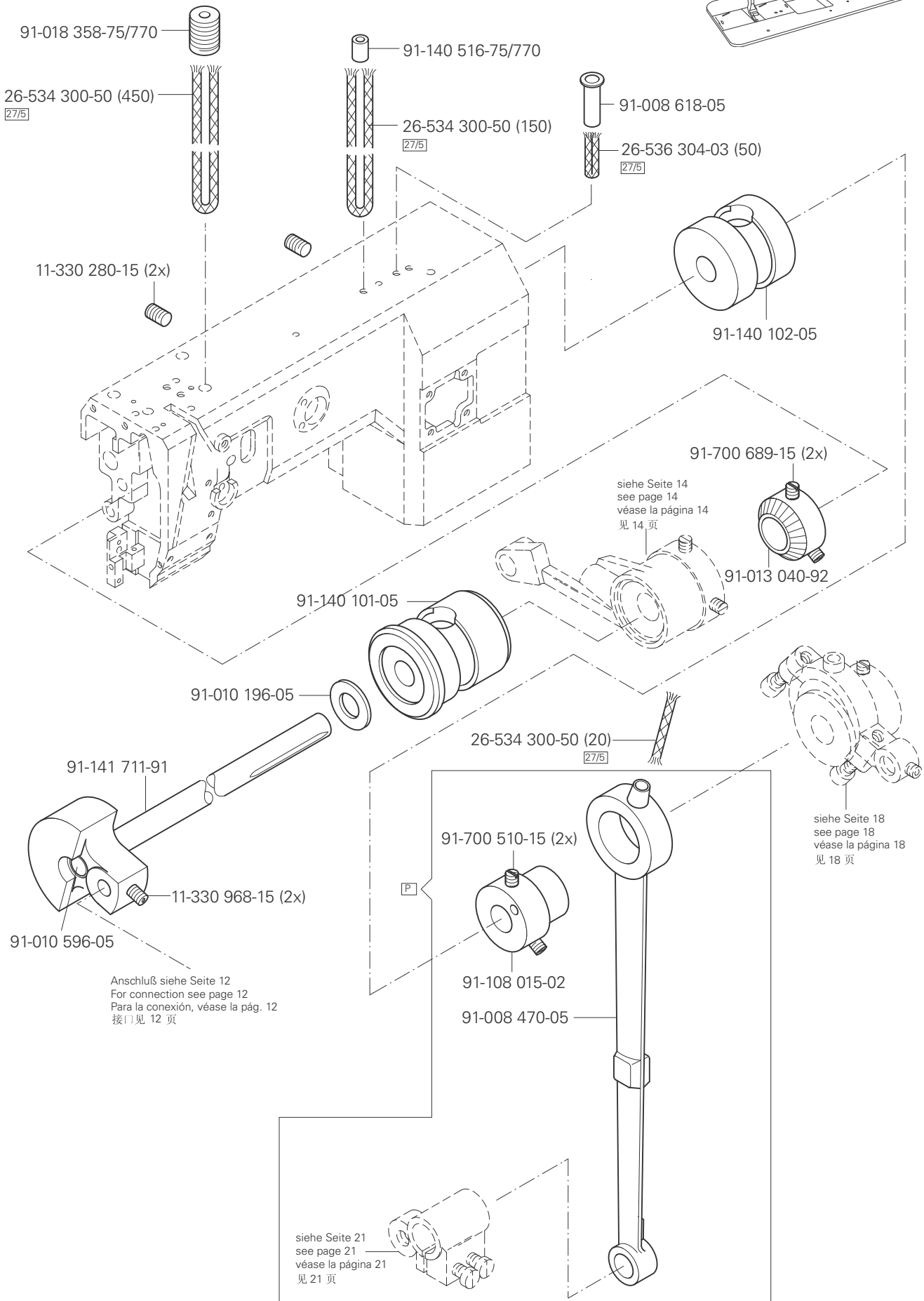
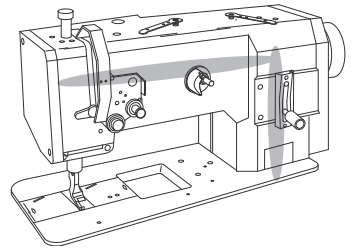



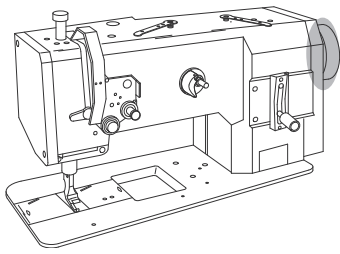

Armteile  
 Arm parts  
 Piezas del brazo  
 机臂零件

MA 1245

3.03

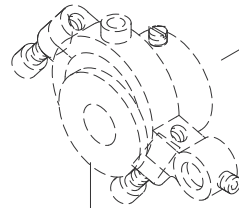
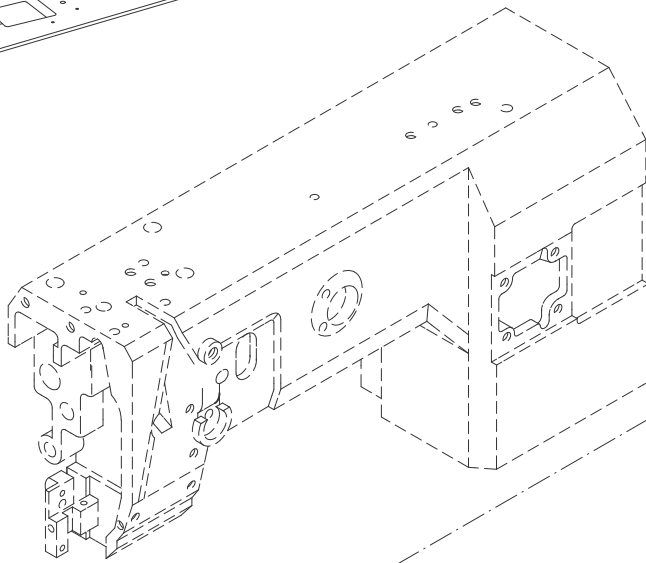

siehe Seite 18  
 see page 18  
 véase la página 18  
 见 18 页

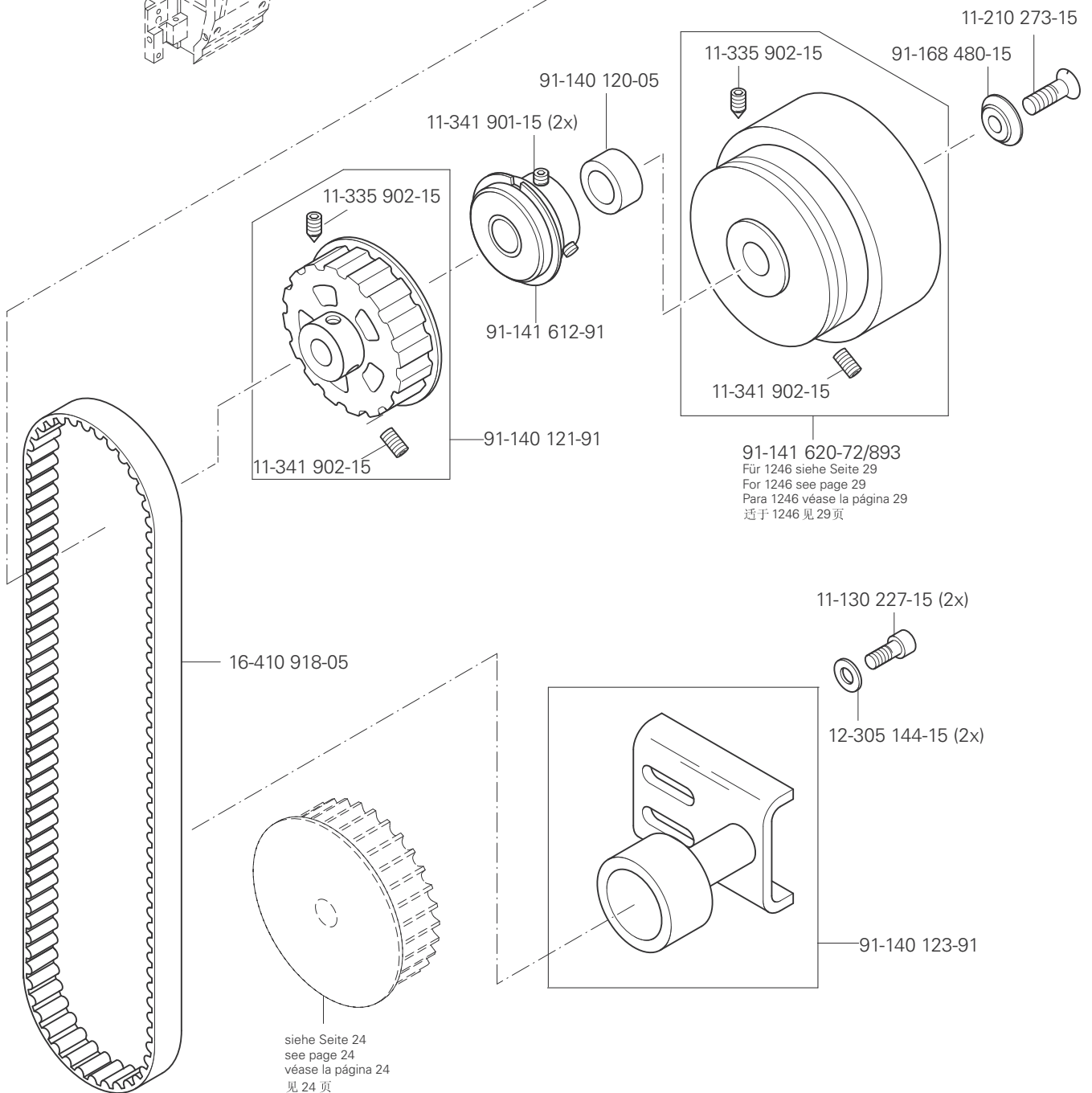

☐ siehe Kapitel 2 Erläuterung der Schlüsselzeichen  
 see chapter 2 Explanation of key markings  
 véase el Cap. 2 Explicación de los signos clave  
 见第 2 章 符号说明

# 3.03

## Armteile Arm parts Piezas del brazo 机臂零件

MA 1245

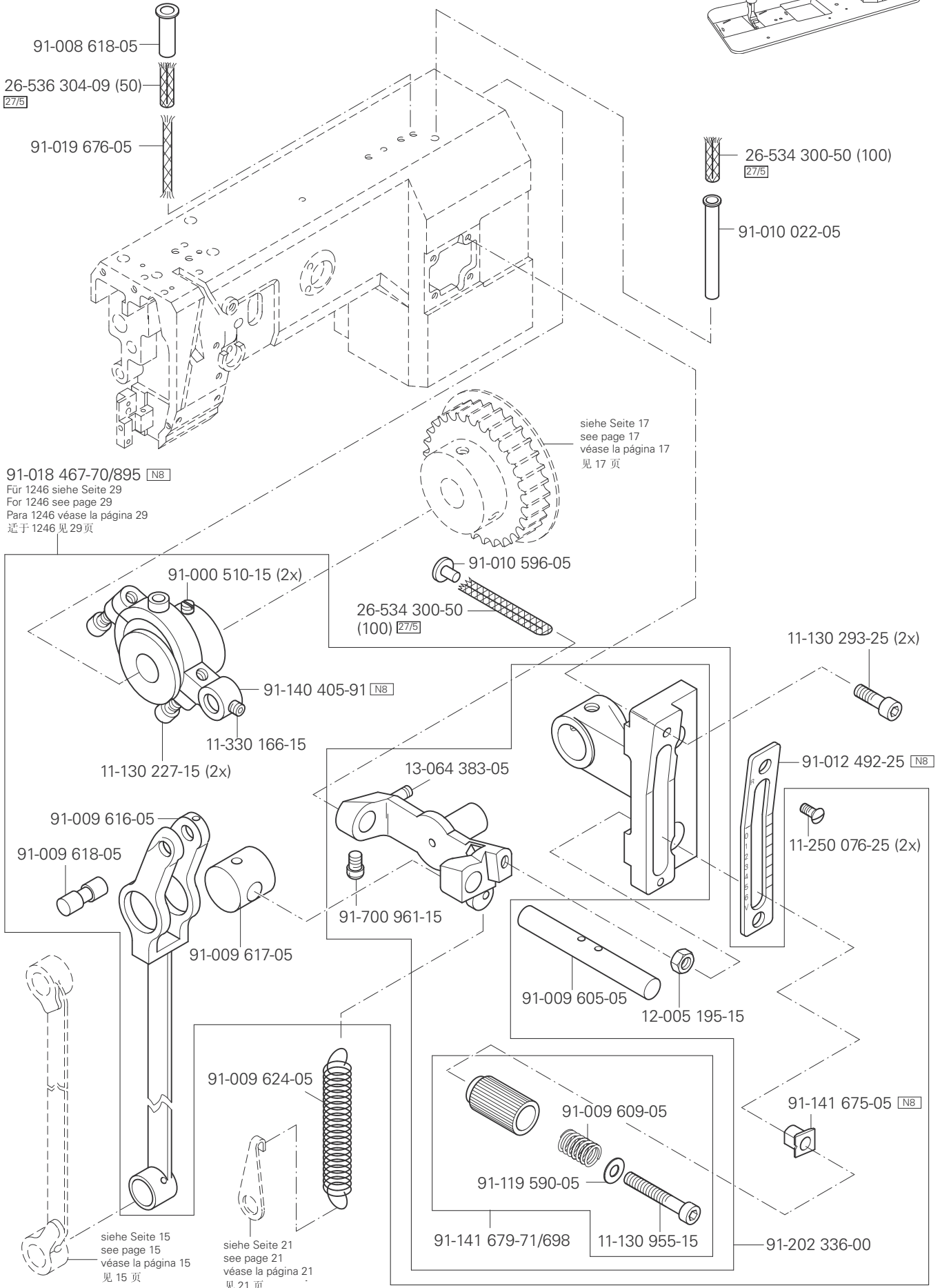
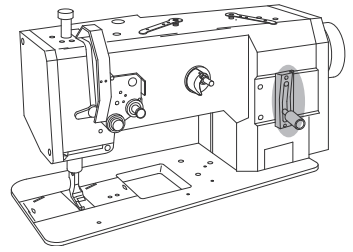

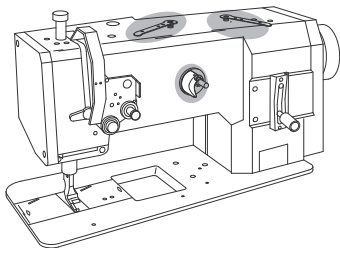

Armteile  
 Arm parts  
 Piezas del brazo  
 机臂零件

MA1245

3.03

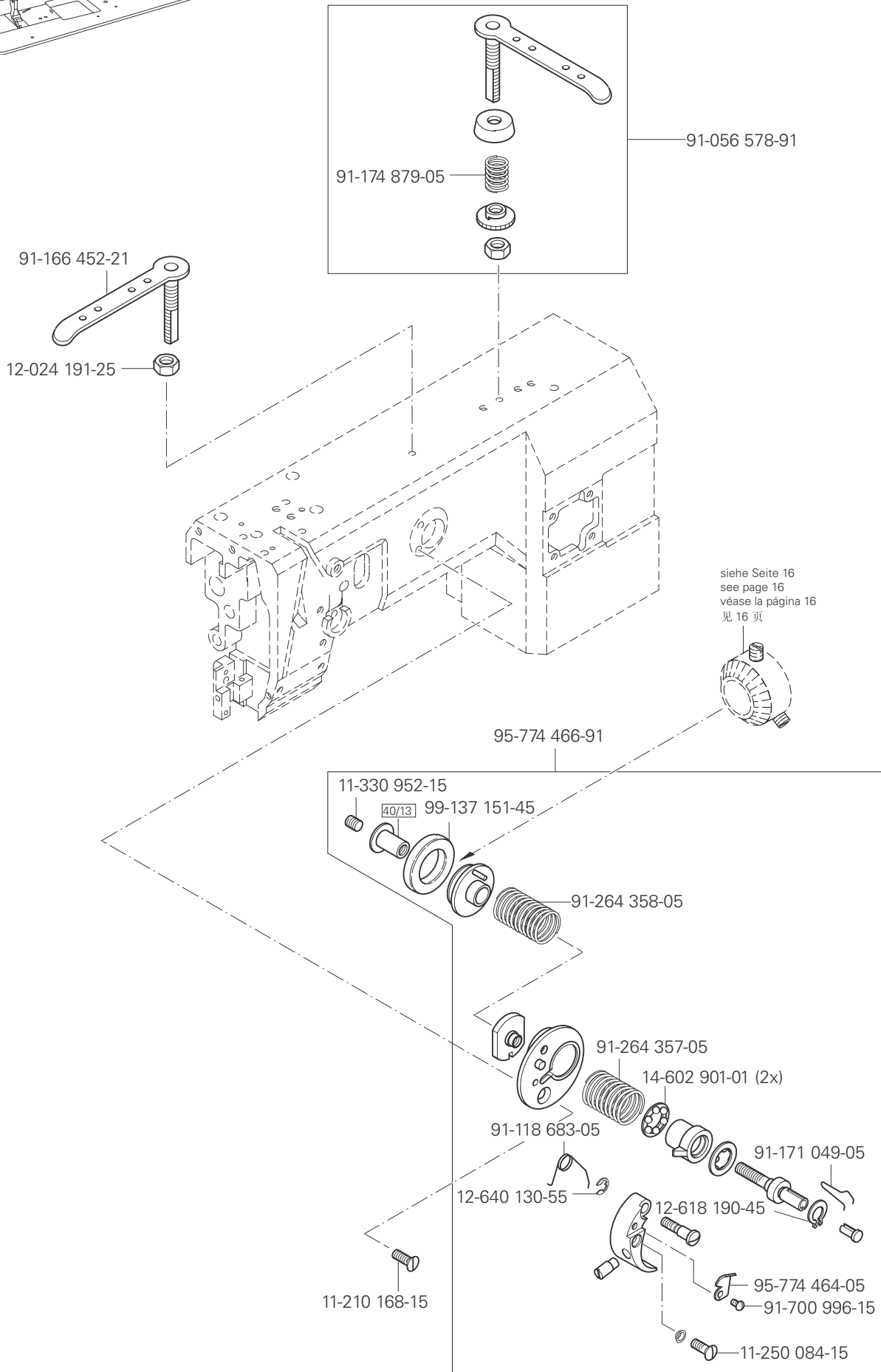

☐ siehe Kapitel 2 Erläuterung der Schlüsselzeichen  
 see chapter 2 Explanation of key markings  
 véase el Cap. 2 Explicaciones de los signos clave  
 见第 2 章 符号说明

# 3.04

## Grundplattenteile Bedplate parts Piezas del cárter 底板零件

MA 1245

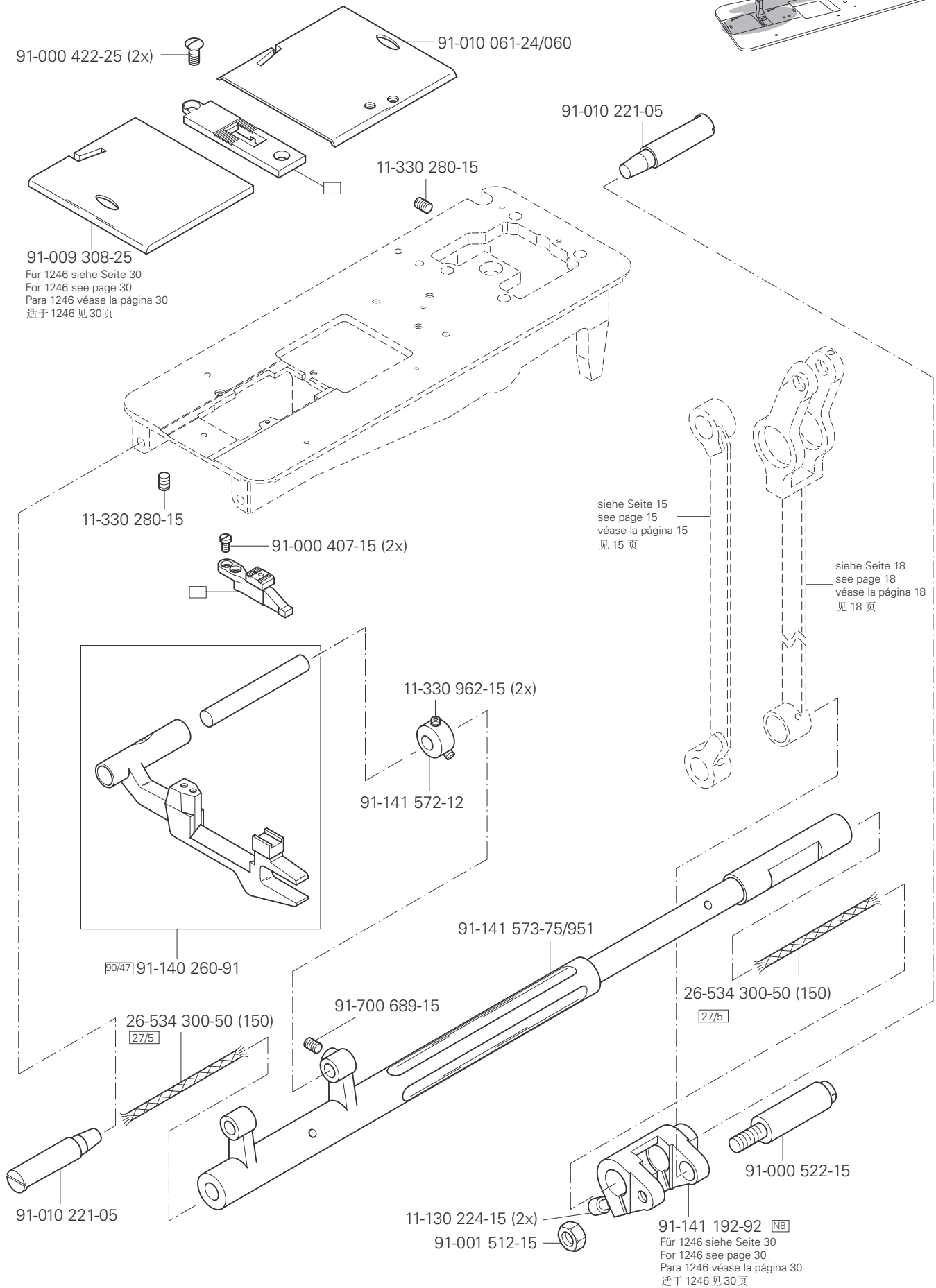
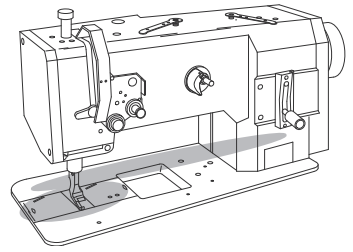

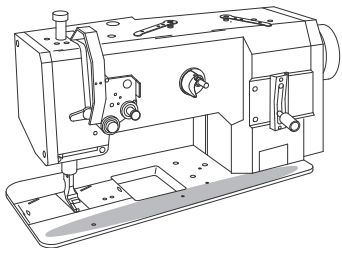

Grundplattenteile  
Bedplate parts  
Piezas del cárter  
底板零件

MA 1245

3.04

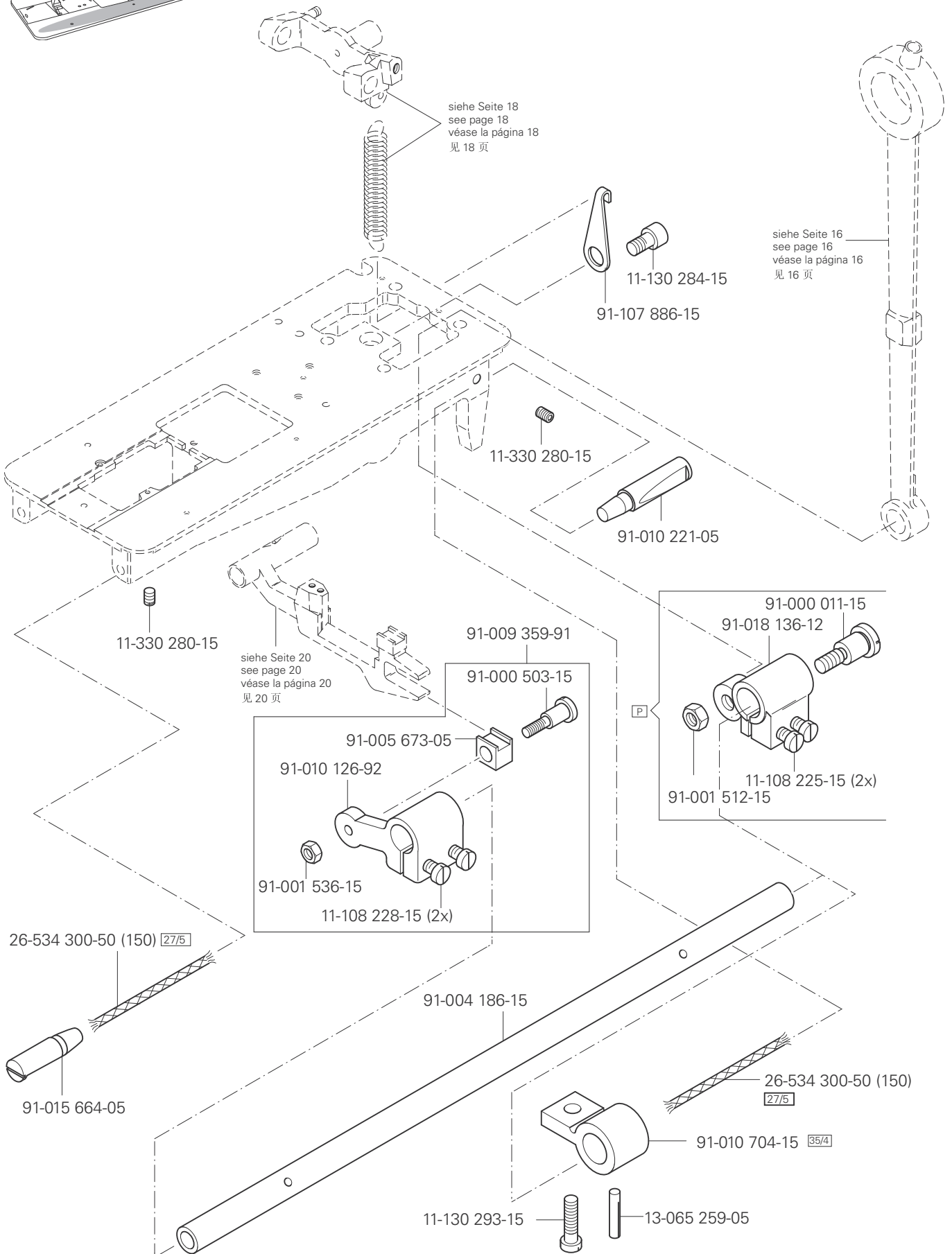

☐ siehe Kapitel 2 Erläuterung der Schlüsselzeichen  
see chapter 2 Explanation of key markings  
véase el Cap. 2 Explicaciones de los signos clave  
见第2章 说明

# 3.04

Grundplattenteile  
Bedplate parts  
Piezas del cárter  
底板零件

MA 1245

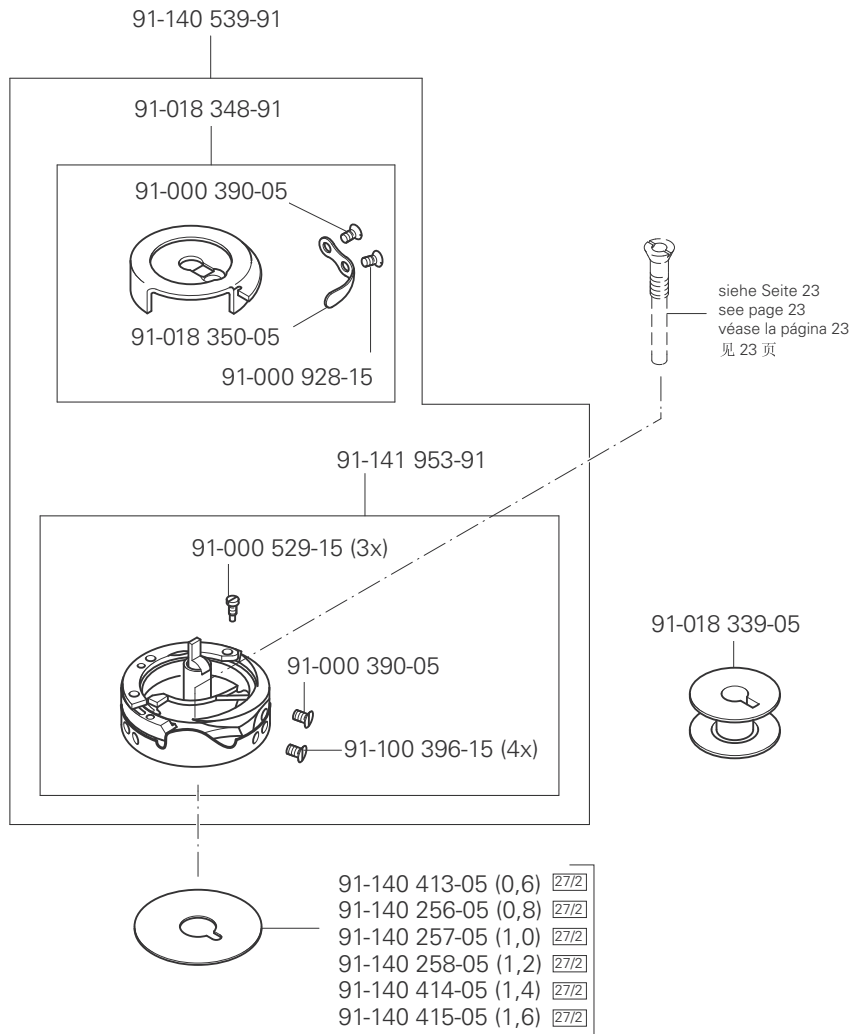
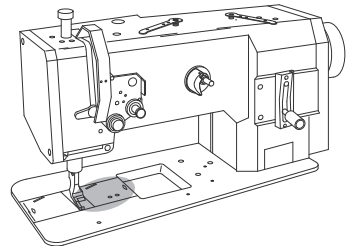

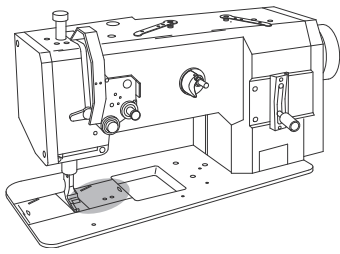



Grundplattenteile  
Bedplate parts  
Piezas del cárter  
底板零件

MA 1245

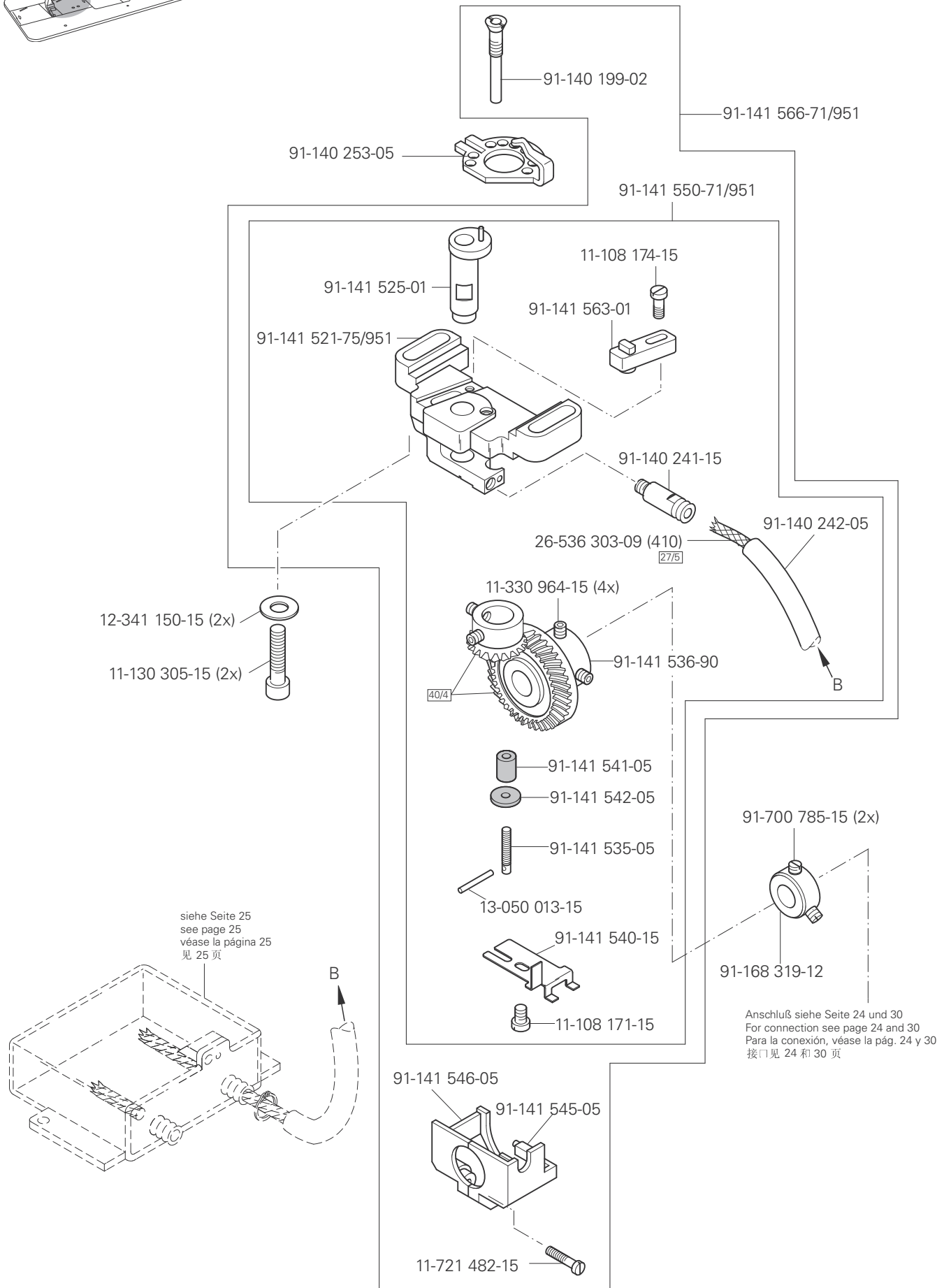
3.04





 siehe Kapitel 2 Erläuterung der Schlüsselzeichen  
 see chapter 2 Explanation of key markings  
 véase el Cap. 2 Explicaciones de los signos clave  
 见第 2 章 说明



# 3.04

Grundplattenteile  
Bedplate parts  
Piezas del cárter  
底板零件

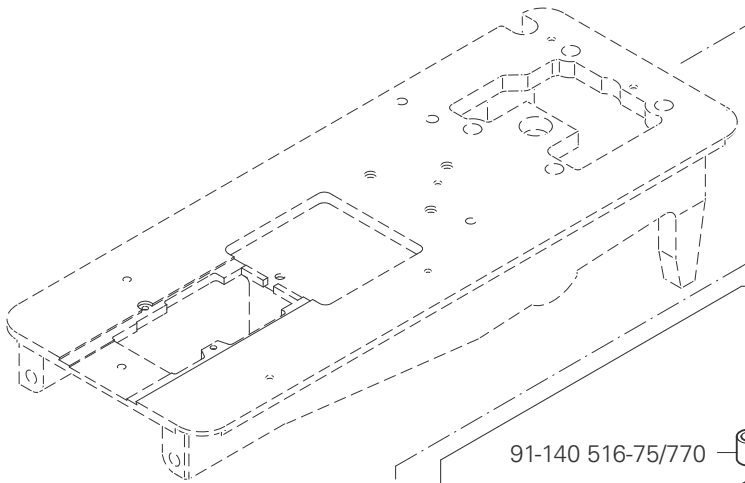
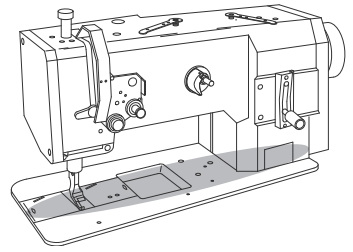
MA 1245



Für 1246 siehe Seite 30  
For 1246 see page 30  
Para 1246 véase la página 30  
适于 1246 见 30 页

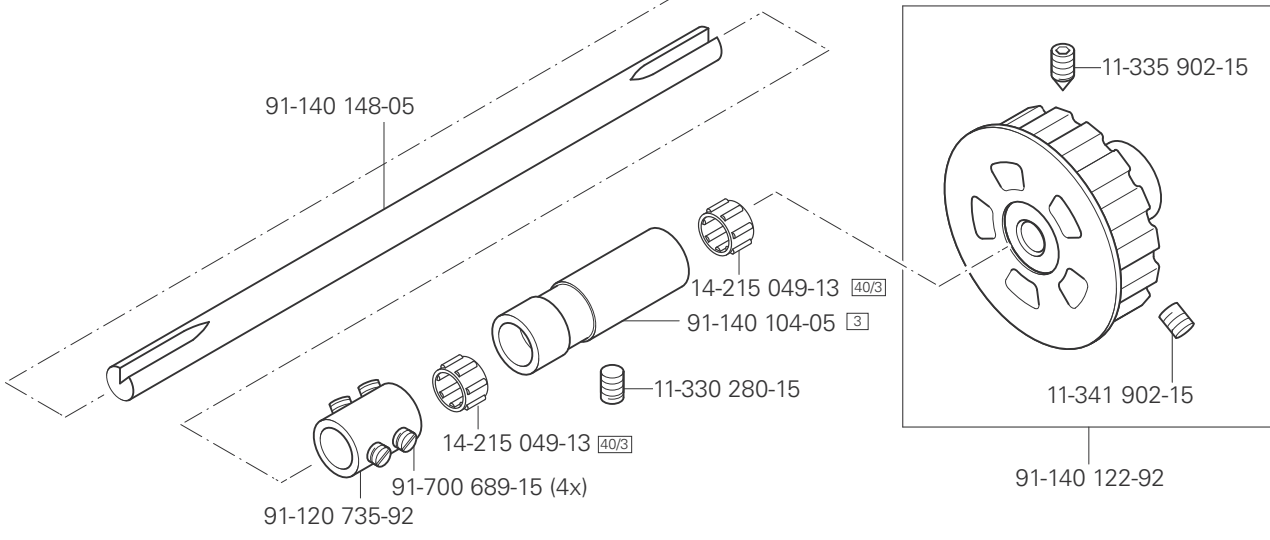
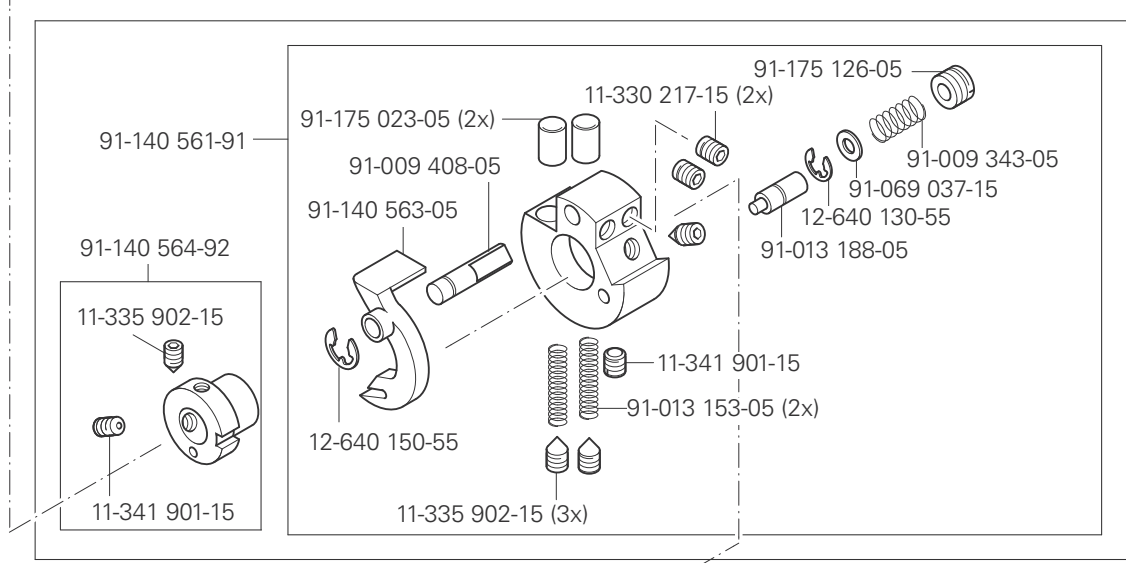
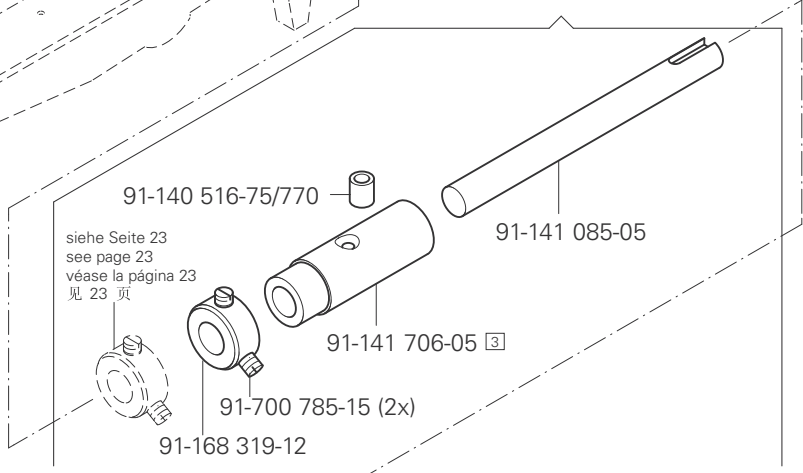



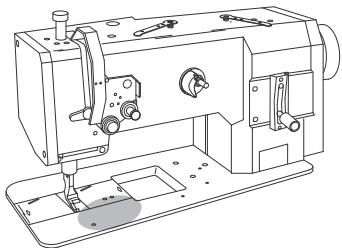

Grundplattenteile  
 Bedplate parts  
 Piezas del cárter  
 底板零件

MA 1245

3.04

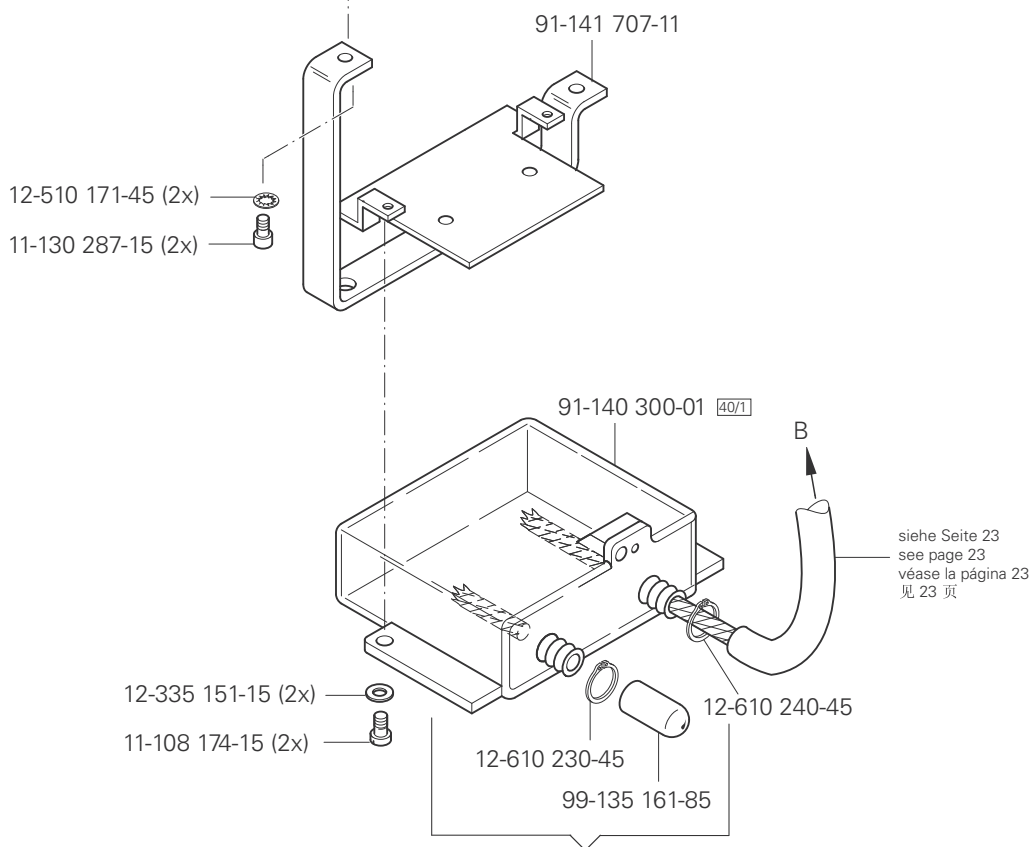
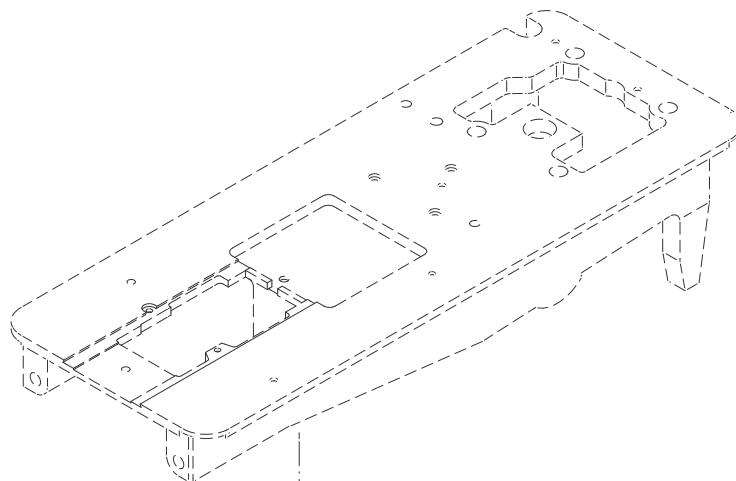

Für 1246 siehe Seite 30  
 For 1246 see page 30  
 Para 1246 véase la página 30  
 适于 1246 见 30 页

# 3.04

## Grundplattenteile Bedplate parts Piezas del cárter 底板零件

MA 1245

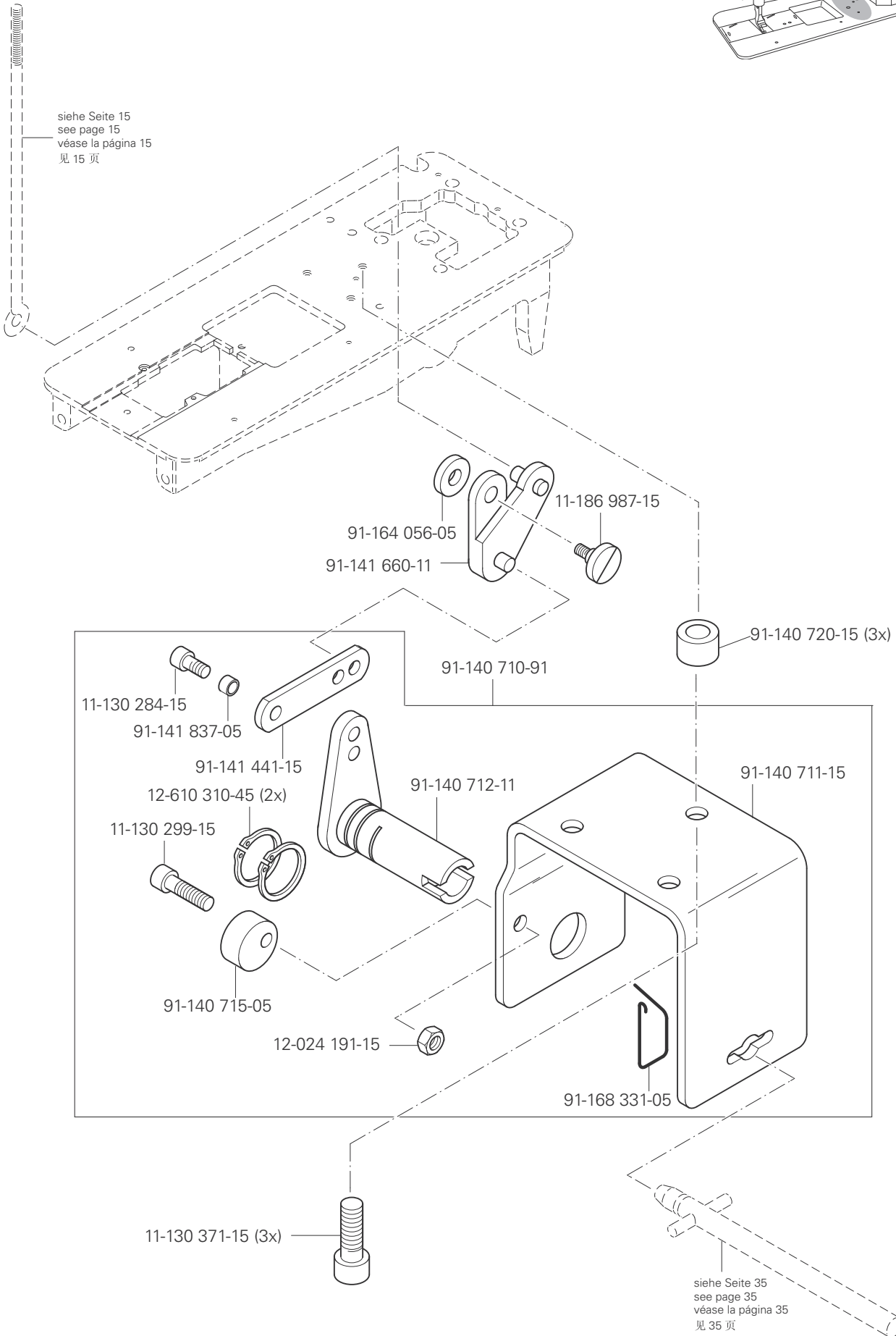
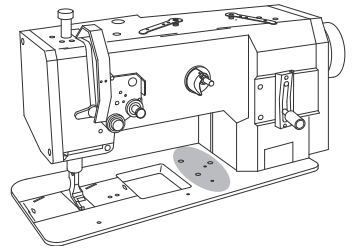

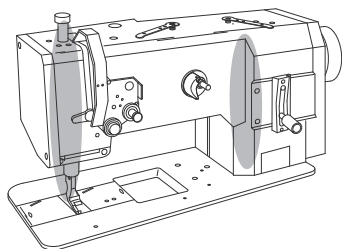

Abweichende Teile der MA 1246  
 Different parts for MA 1246  
 Piezas de la MA 1246 que son diferentes  
 MA 1246 中有差别的零件

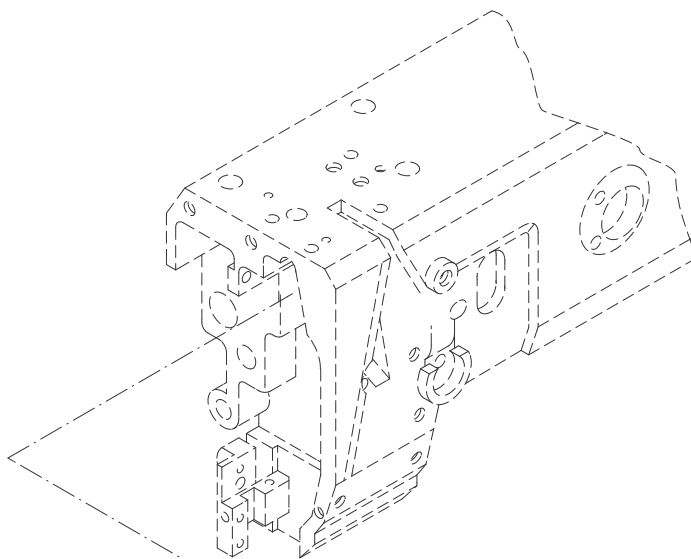

siehe Seite 10  
 see page 10  
 véase la página 10  
 见 10 页

siehe Seite 15  
 see page 15  
 véase la página 15  
 见 15 页

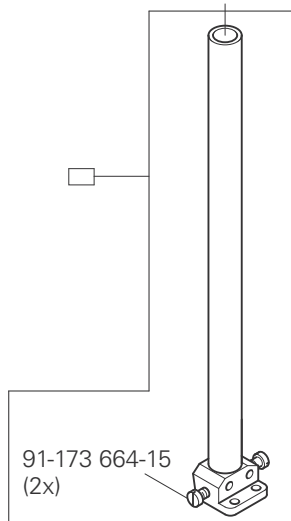
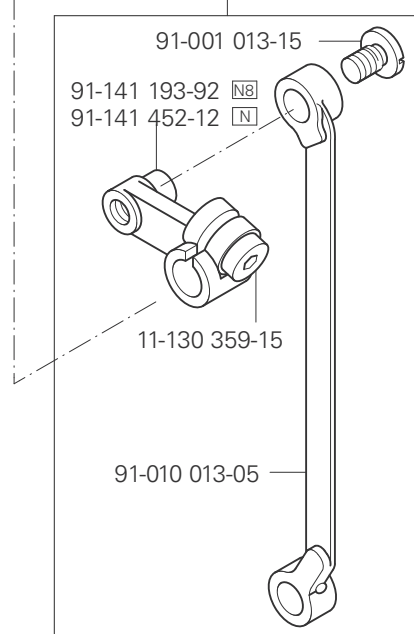
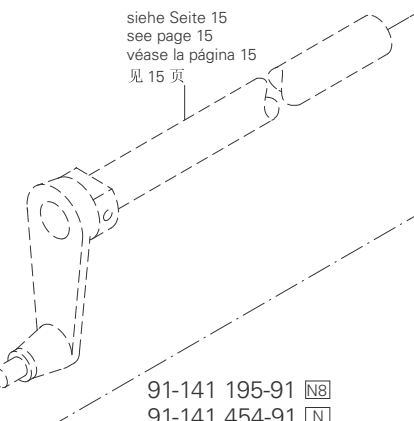
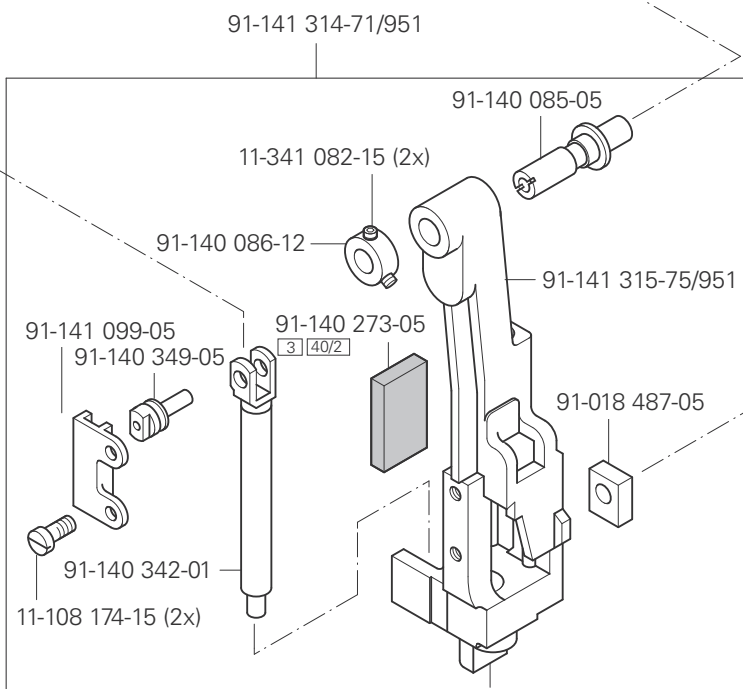

☐ siehe Kapitel 2 Erläuterung der Schlüsselzeichen  
 see chapter 2 Explanation of key markings  
 véase el Cap. 2 Explicaciones de los signos clave  
 见第2章的说明

(die sonstigen Teile wie in Register 3.01 bis 3.04)  
 (for all other parts see Sections 3.01 to 3.04)  
 (las demás piezas como en los registros 3.01 al 3.04)  
 (其他零件如第3.01至3.04章中所列)

# 4

Abweichende Teile der MA 1246  
 Different parts for MA 1246  
 Piezas de la MA 1246 que son diferentes  
 MA 1246 中有差别的零件

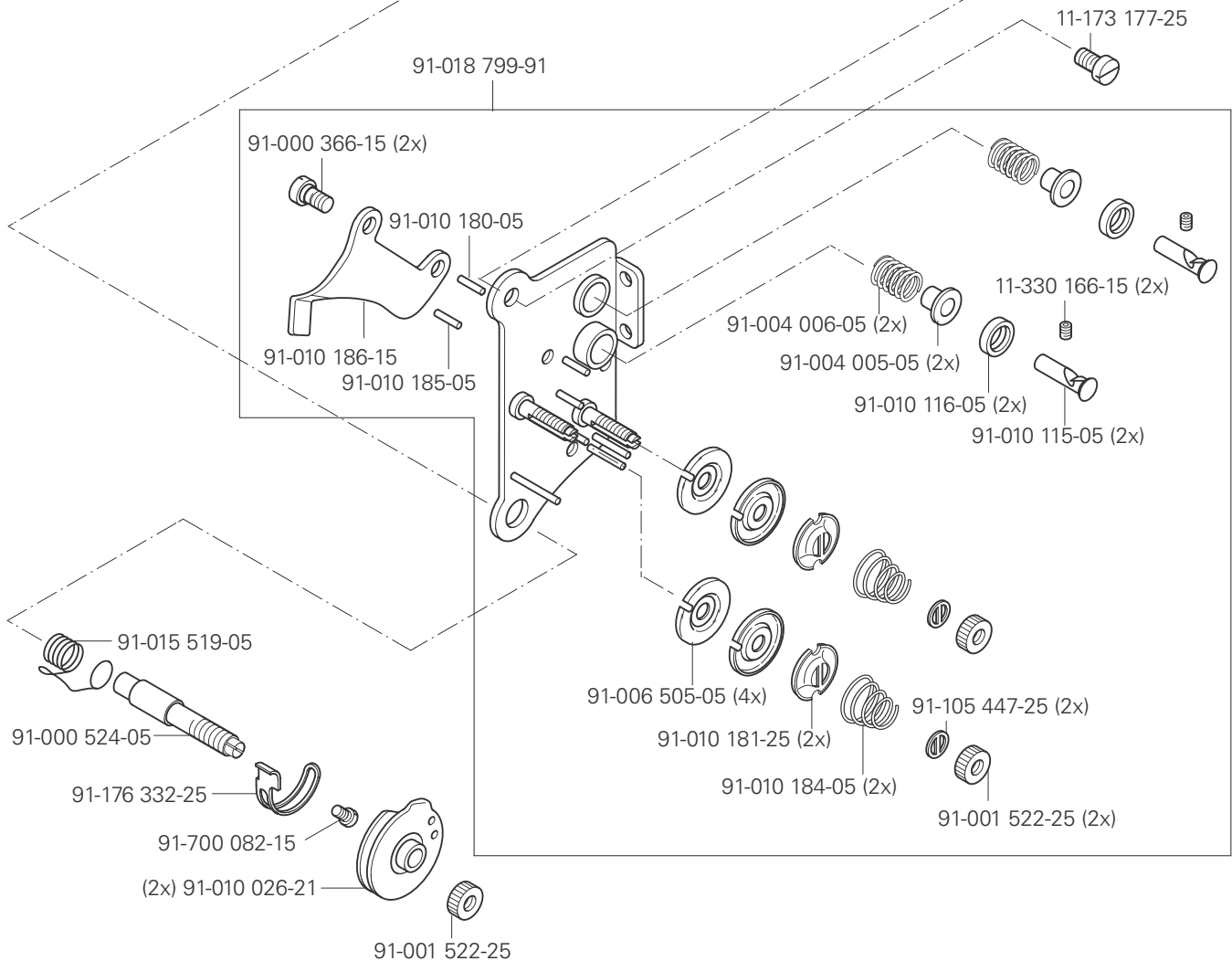
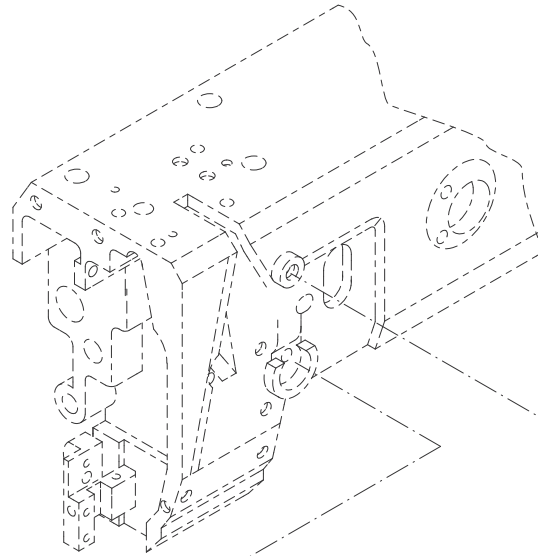
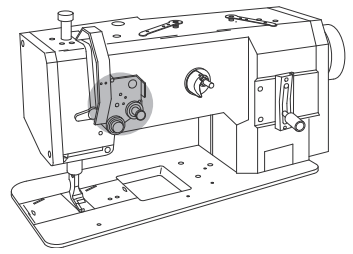

Abweichende Teile der MA 1246  
 Different parts for MA 1246  
 Piezas de la MA 1246 que son diferentes  
 MA 1246 中有差别的零件

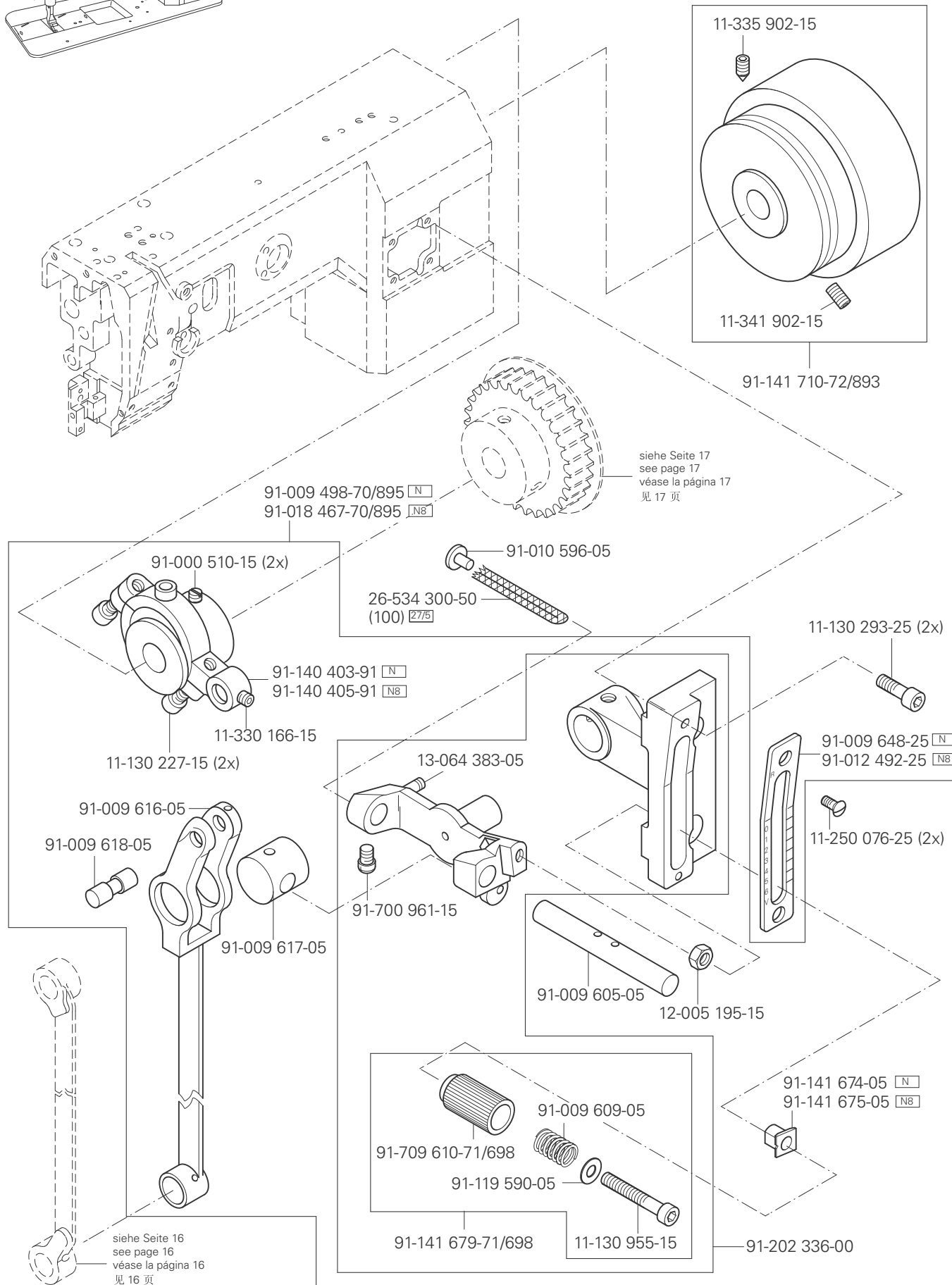
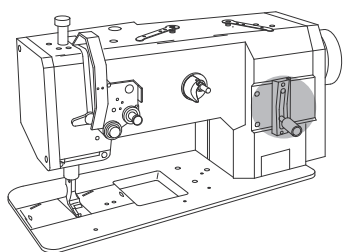

siehe Kapitel 2 Erläuterung der Schlüsselzeichen  
 see chapter 2 Explanation of key markings  
 véase el Cap. 2 Explicaciones de los signos clave  
 见第2章的说明

(die sonstigen Teile wie in Register 3.01 bis 3.04)  
 (for all other parts see Sections 3.01 to 3.04)  
 (las demás piezas como en los registros 3.01 al 3.04)  
 (其他零件如见 3.01 至 3.04 章的目录)

# 4

## Abweichende Teile der MA 1246 Different parts for MA 1246 Piezas de la MA 1246 que son diferentes MA 1246 中有差别的零件

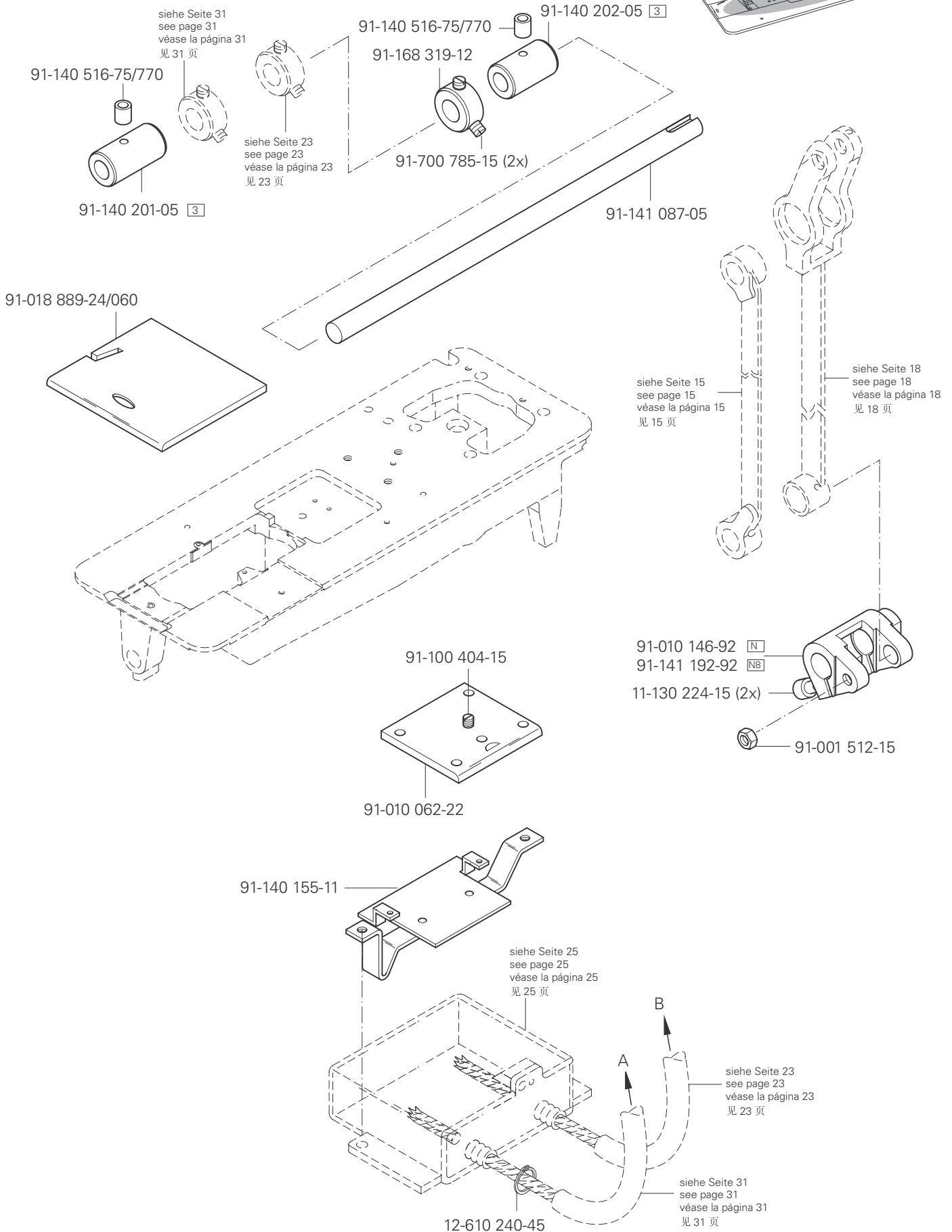
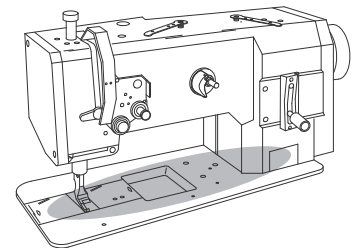

Abweichende Teile der MA 1246  
 Different parts for MA 1246  
 Piezas de la MA 1246 que son diferentes  
 MA 1246 中有差别的零件

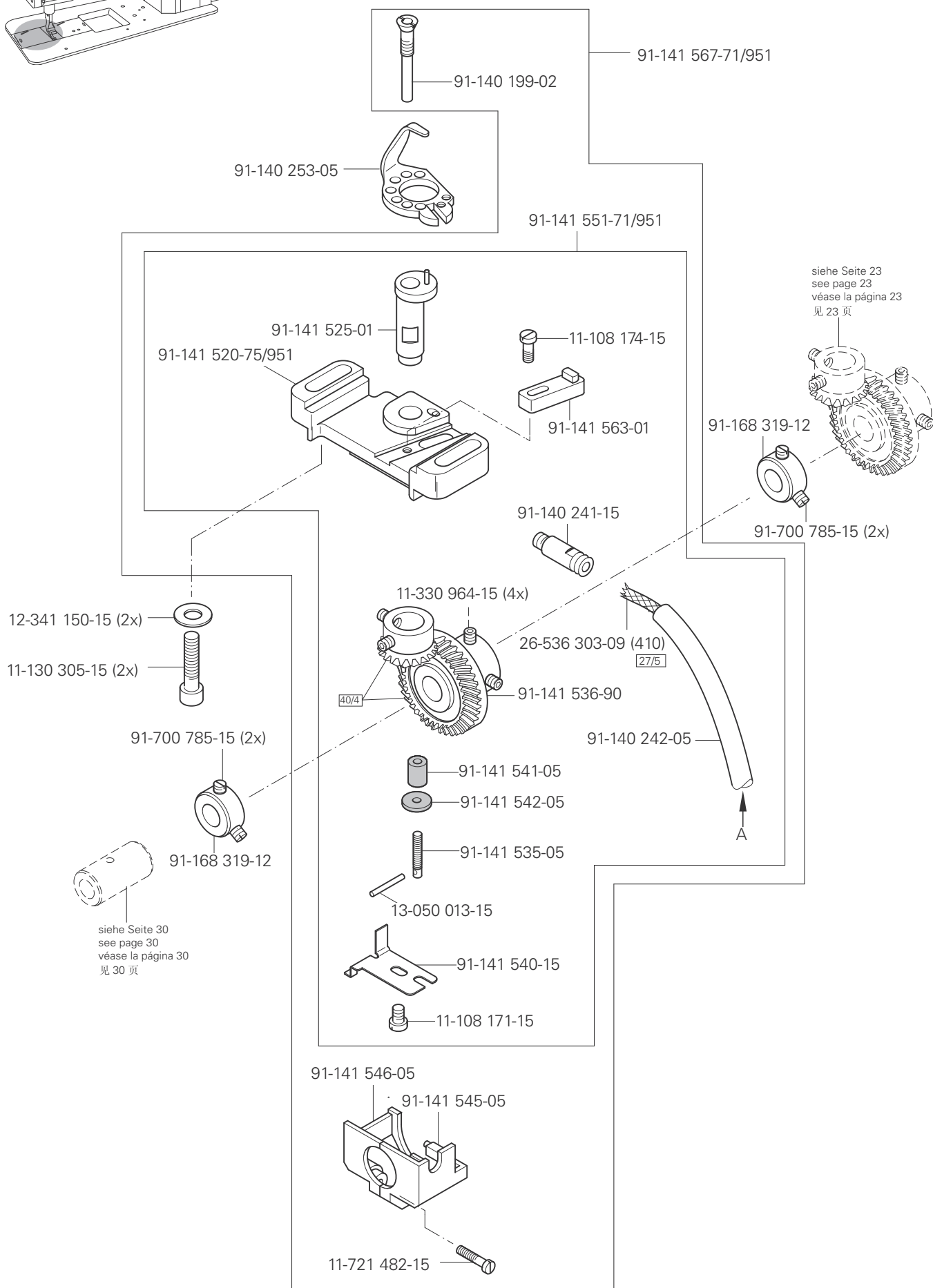
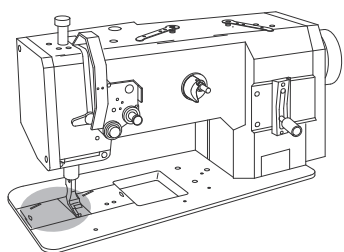

☐ siehe Kapitel 2 Erläuterung der Schlüsselzeichen  
 see chapter 2 Explanation of key markings  
 véase el Cap. 2 Explicaciones de los signos clave

(die sonstigen Teile wie in Register 3.01 bis 3.04)  
 (for all other parts see Sections 3.01 to 3.04)  
 (las demás piezas como en los registros 3.01 al 3.04)

# 5

Nähfuß heben über Pedal (-910/01)  
 Raiser presser foot via the pedal (-910/01)  
 Elevación del prensatelas mediante pedal (-910/01)  
 用踏板抬起压脚 (-910/01)

MA 1245

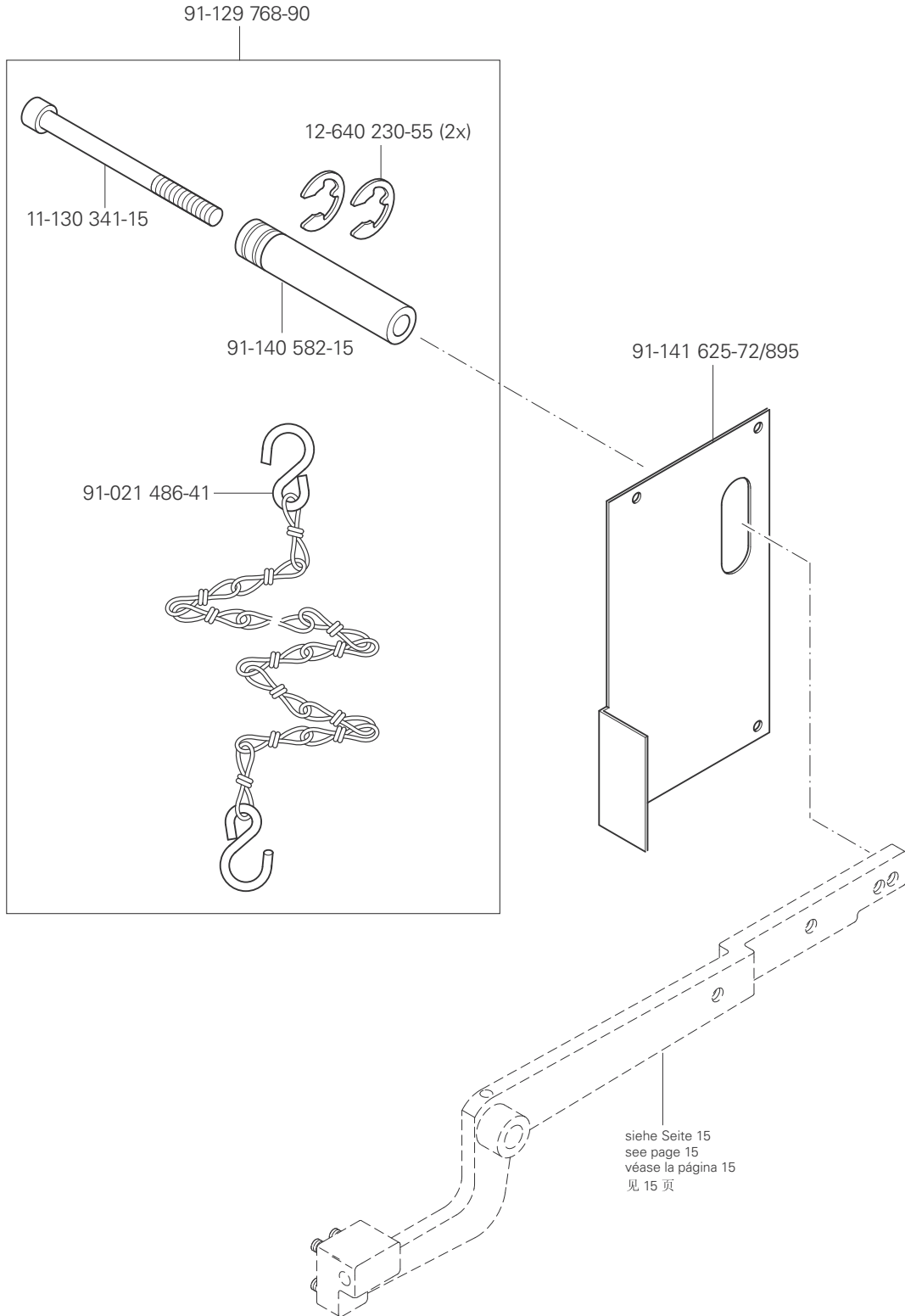
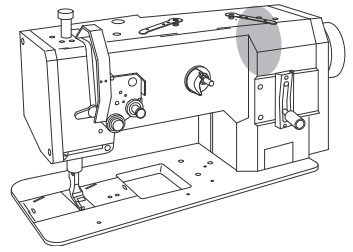



91-229 070-70/895

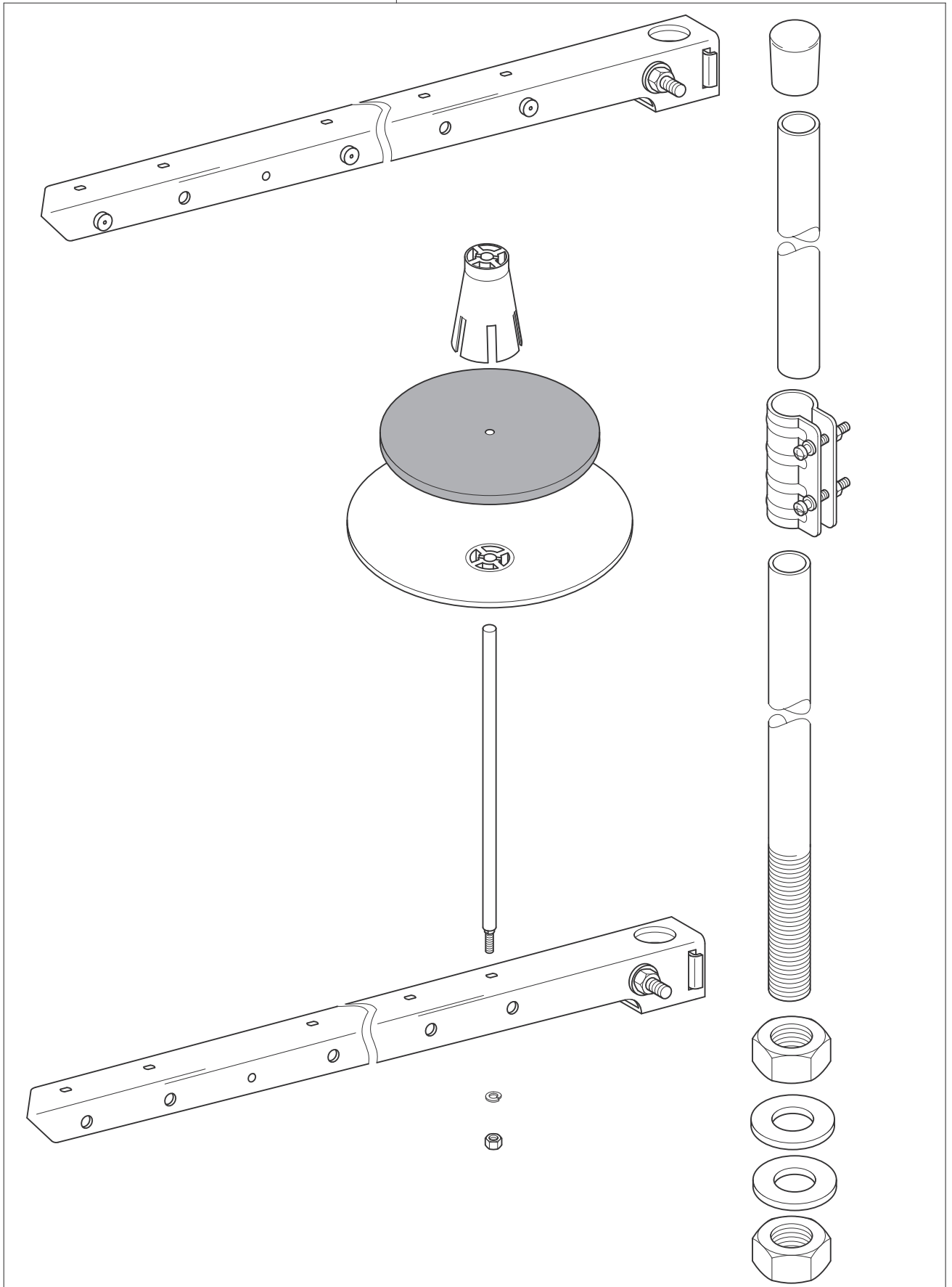

# 7

Einstellehren  
Adjustment gauges  
Calibres de ajuste  
设置量规

MA 1245  
MA 1246

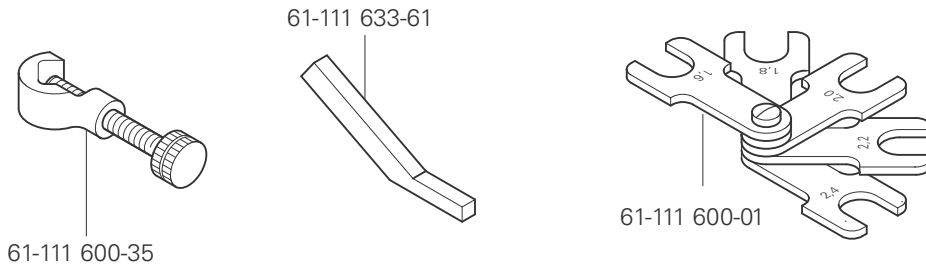

# 8

Teile zur Tischplatte  
Parts for table top  
Piezas para el tablero  
用于台板的零件

MA 1245  
MA 1246

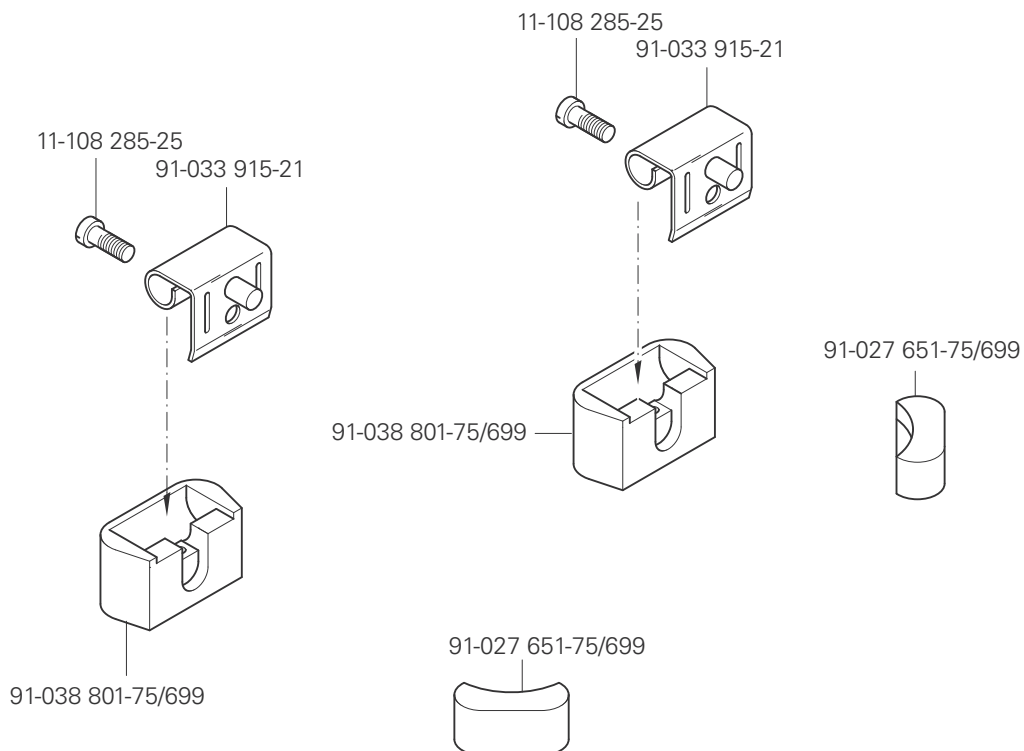

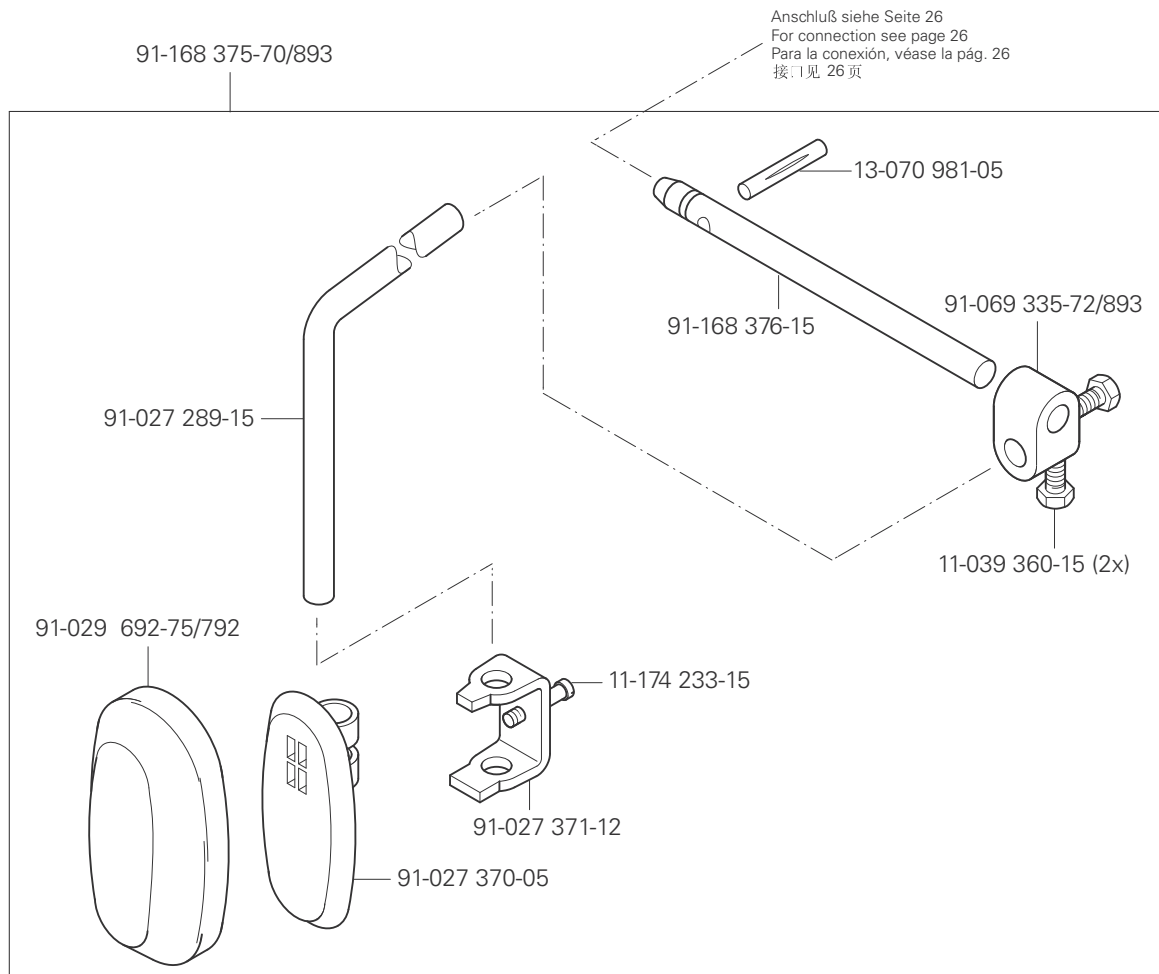
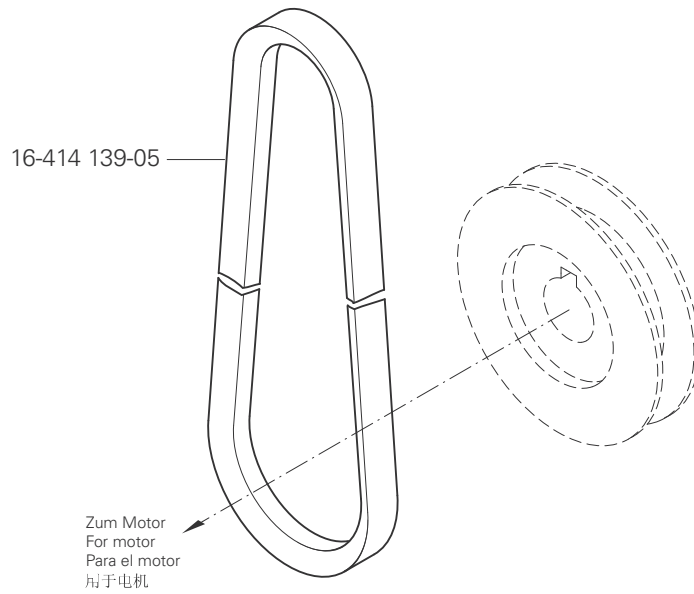

Öl Oil Aceite 油	Mittelpunkts-Viskosität bei: Mean viscosity at: Viscosidad media a: 中点粘度:		Dichte bei: Density of: Densidad a: 密度, 在:		Bestellnummer für Behälter mit: Part number for can with: Número de pedido para recipientes con: 订货号用于油箱, 带:		
	°C	mm <sup>2</sup> /s	°C	g/cm <sup>3</sup> (g/ml)	1 Liter 1 Litre 1 Litro 1 升		
28-011 201-44	40	22,0	15	0,865	91-129 917-91		

Fett Grease Grasa 脂	Penetration Penetration Penetración 贯入度	Tropfpunkt Drip-point Punto de goteo 贯入度	Bestellnummer für Behälter mit: Part number for can with: Número de pedido para recipientes con: 订货号用于油箱, 带:				
			mm/10	°C	0,25 kg	0,5 kg	1 kg
28-011 202-05							28-011 205-05
28-011 202-43	375-405	150			28-011 202-43		
28-011 202-47	220-250	185					28-011 202-47

No. 零件号	Seite Page Página 页号	No. 零件号	Seite Page Página 页号	No. 零件号	Seite Page Página 页号	No. 零件号	Seite Page Página 页号
11-039 222-15	14	11-173 171-75	9	12-024 191-25	19	26-536 304-09	12, 18
11-039 225-15	14	11-173 177-25	13, 28	12-305 114-15	11	28-011 201-44	36
11-039 360-15	35	11-173 222-15	9	12-305 144-15	11, 17	28-011 202-05	36
11-108 093-15	11	11-174 089-15	11	12-335 151-15	25	28-011 202-43	36
11-108 171-15	11, 23, 31	11-174 173-15	10	12-335 171-15	14	28-011 202-47	36
11-108 174-15	11, 23, 25, 27, 31	11-174 233-15	13, 35	12-341 150-15	23, 31	61-111 600-01	34
11-108 177-15	11	11-186 987-15	26	12-510 171-45	25	61-111 600-35	34
11-108 177-25	12	11-187 017-15	15	12-610 170-45	10	61-111 633-61	34
11-108 222-15	11	11-210 165-15	13	12-610 190-45	10	91-000 011-15	21
11-108 225-15	9, 21	11-210 168-15	19	12-610 200-45	10	91-000 366-15	13, 28
11-108 228-15	10, 14, 21	11-210 273-15	17	12-610 230-45	25	91-000 390-05	22
11-108 234-15	9	11-250 076-25	18, 29	12-610 240-45	25, 30	91-000 407-15	20
11-108 285-15	9	11-250 084-15	19	12-610 310-45	26	91-000 422-25	20
11-108 285-25	34	11-330 166-15	13, 18, 28, 29	12-618 190-45	19	91-000 503-15	21
11-130 173-15	11	11-330 217-15	24	12-640 130-55	19, 24	91-000 510-15	18, 29
11-130 185-15	11	11-330 220-15	11, 13	12-640 150-55	24	91-000 522-15	20
11-130 224-15	11, 20, 30	11-330 280-15	10, 11, 12, 16, 20, 21, 24	12-640 170-55	13	91-000 524-05	13, 28
11-130 227-15	17, 18, 29	11-330 952-15	15, 19	12-640 230-55	32	91-000 529-15	22
11-130 254-15	9	11-330 962-15	20	13-050 013-15	23, 31	91-000 928-15	22
11-130 284-15	21, 26	11-330 964-15	23, 31	13-064 383-05	13, 18, 29	91-001 013-15	15, 27
11-130 287-15	25	11-330 968-15	14, 16	13-065 259-05	21	91-001 512-15	20, 21, 30
11-130 293-15	21	11-335 902-15	17, 24, 29	13-070 981-05	35	91-001 522-25	13, 28
11-130 293-25	18, 29	11-341 082-15	11, 27	14-215 049-13	24	91-001 536-15	21
11-130 299-15	26	11-341 901-15	17, 24	14-602 901-01	19	91-003 113-05	9
11-130 305-15	23, 31	11-341 902-15	17, 24, 29	15-711 050-51	14	91-004 005-05	13, 28
11-130 341-15	32	11-462 118-55	9	16-410 918-05	17	91-004 006-05	13, 28
11-130 359-15	15, 27	11-721 482-15	23, 31	16-414 139-05	35	91-004 186-15	21
11-130 371-15	26	12-005 195-15	18, 29	26-534 300-50	12, 16, 18, 20, 21, 29	91-004 309-05	10
11-130 906-15	9	12-024 171-25	15	26-536 303-09	23, 31	91-005 673-05	21
11-130 955-15	18, 29	12-024 191-15	26	26-536 304-03	16	91-006 505-05	13, 28

No. 零件号	Seite Page Página 页号	No. 零件号	Seite Page Página 页号	No. 零件号	Seite Page Página 页号	No. 零件号	Seite Page Página 页号
91-008 470-05	16	91-010 221-05	20, 21	91-029 692-75/792	35	91-140 120-05	17
91-008 618-05	16, 18	91-010 596-05	16, 18, 29	91-032 087-45	9	91-140 121-91	17
91-009 308-25	20	91-010 704-15	21	91-033 915-21	34	91-140 122-92	24
91-009 343-05	24	91-010 825-05	14	91-038 801-75/699	34	91-140 123-91	17
91-009 359-91	21	91-010 937-05	13	91-056 578-91	19	91-140 148-05	24
91-009 408-05	24	91-011 778-05	14	91-057 720-15	11	91-140 155-11	30
91-009 498-70/895	29	91-012 492-25	18, 29	91-063 048-05	12	91-140 199-02	23, 31
91-009 605-05	18, 29	91-013 040-92	16	91-069 037-15	24	91-140 201-05	30
91-009 609-05	18, 29	91-013 091-05	13	91-069 335-72/893	35	91-140 202-05	30
91-009 616-05	18, 29	91-013 153-05	24	91-100 213-05	12	91-140 241-15	23, 31
91-009 617-05	18, 29	91-013 188-05	24	91-100 366-15	10	91-140 242-05	23, 31
91-009 618-05	18, 29	91-013 191-05	13	91-100 396-15	22	91-140 253-05	23, 31
91-009 624-05	18	91-013 193-91	13	91-100 404-15	30	91-140 256-05	22
91-009 648-25	29	91-015 519-05	28	91-105 447-25	13, 28	91-140 257-05	22
91-009 652-91	13	91-015 664-05	21	91-107 669-75/895	9	91-140 258-05	22
91-010 013-05	15, 27	91-018 136-12	21	91-107 886-15	21	91-140 260-91	20
91-010 022-05	18	91-018 339-05	22	91-108 015-02	16	91-140 273-05	11, 27
91-010 026-21	13, 28	91-018 348-91	22	91-118 196-12	10	91-140 292-91	14
91-010 061-24/060	20	91-018 350-05	22	91-118 430-25	13	91-140 300-01	25
91-010 062-22	30	91-018 358-75/770	16	91-118 683-05	19	91-140 336-15	15
91-010 115-05	13, 28	91-018 467-70/895	18, 29	91-119 421-05	14	91-140 342-01	11, 27
91-010 116-05	13, 28	91-018 487-05	11, 27	91-119 590-05	18, 29	91-140 347-01	10
91-010 126-92	21	91-018 799-91	28	91-120 735-92	24	91-140 349-05	10, 11, 27
91-010 146-92	30	91-018 889-24/060	30	91-129 768-90	32	91-140 351-91	10
91-010 180-05	28	91-019 676-05	18	91-129 917-91	36	91-140 352-05	10
91-010 181-25	13, 28	91-021 486-41	32	91-140 085-05	11, 27	91-140 353-05	10
91-010 184-05	13, 28	91-027 289-15	35	91-140 086-12	11, 27	91-140 358-05	10
91-010 185-05	13, 28	91-027 370-05	35	91-140 101-05	16	91-140 359-05	10
91-010 186-15	13, 28	91-027 371-12	35	91-140 102-05	16	91-140 360-05	10
91-010 196-05	16	91-027 651-75/699	34	91-140 104-05	24	91-140 363-12	10

No. 零件号	Seite Page Página 页号	No. 零件号	Seite Page Página 页号	No. 零件号	Seite Page Página 页号	No. 零件号	Seite Page Página 页号
91-140 366-05	10	91-141 100-91	11	91-141 550-71/951	23	91-141 679-71/698	18, 29
91-140 367-05	10	91-141 101-15	11	91-141 551-71/951	31	91-141 687-70/698	9
91-140 368-05	10	91-141 102-05	11	91-141 563-01	23, 31	91-141 694-05	14
91-140 372-05	10	91-141 192-92	20, 30	91-141 566-71/951	23	91-141 706-05	24
91-140 378-05	14	91-141 193-92	15, 27	91-141 567-71/951	31	91-141 707-11	25
91-140 379-92	14	91-141 195-91	15, 27	91-141 572-12	20	91-141 710-72/893	29
91-140 394-05	10	91-141 307-05	11	91-141 573-75/951	20	91-141 711-91	16
91-140 403-91	29	91-141 312-71/951	11	91-141 608-91	11	91-141 829-92	15
91-140 405-91	18, 29	91-141 313-75/951	11	91-141 609-01	11	91-141 831-15	15
91-140 413-05	22	91-141 314-71/951	27	91-141 610-05	11	91-141 837-05	26
91-140 414-05	22	91-141 315-75/951	27	91-141 612-91	17	91-141 848-91	14
91-140 415-05	22	91-141 426-15	9	91-141 617-75/698	9	91-141 850-91	10
91-140 450-25	10	91-141 427-15	9	91-141 618-75/895	9	91-141 851-91	10
91-140 481-01	15	91-141 428-15	9	91-141 620-72/893	17	91-141 852-91	10
91-140 516-75/770	16, 24, 30	91-141 441-15	26	91-141 621-75/895	9	91-141 853-91	14
91-140 539-91	22	91-141 442-15	13	91-141 624-75/895	9	91-141 953-91	22
91-140 560-90	24	91-141 443-15	13	91-141 625-72/895	32	91-164 056-05	26
91-140 561-91	24	91-141 452-12	27	91-141 626-05	15	91-166 452-21	19
91-140 563-05	24	91-141 454-91	27	91-141 628-75/895	9	91-166 559-25	13
91-140 564-92	24	91-141 502-15	13	91-141 660-11	26	91-168 025-05	12
91-140 576-91	12	91-141 520-75/951	31	91-141 662-15	15	91-168 319-12	23, 24, 30, 31
91-140 582-15	32	91-141 521-75/951	23	91-141 663-15	15	91-168 331-05	26
91-140 710-91	26	91-141 525-01	23, 31	91-141 664-72/895	9	91-168 375-70/893	35
91-140 711-15	26	91-141 535-05	23, 31	91-141 665-91	9	91-168 376-15	35
91-140 712-11	26	91-141 536-90	23, 31	91-141 666-05	11	91-168 480-15	17
91-140 715-05	26	91-141 540-15	23, 31	91-141 667-05	11	91-169 523-05	14
91-140 720-15	26	91-141 541-05	23, 31	91-141 668-15	13	91-171 049-05	19
91-141 085-05	24	91-141 542-05	23, 31	91-141 674-05	29	91-171 808-05	10
91-141 087-05	30	91-141 545-05	23, 31	91-141 675-05	18, 29	91-173 664-15	27
91-141 099-05	11, 27	91-141 546-05	23, 31	91-141 676-15	9	91-174 879-05	19

No. 零件号	Seite Page Página 页号	No. 零件号	Seite Page Página 页号	No. 零件号	Seite Page Página 页号	No. 零件号	Seite Page Página 页号
91-175 023-05	24						
91-175 126-05	24						
91-176 267-05	10						
91-176 332-25	13, 28						
91-202 336-00	18, 29						
91-229 070-70/895	33						
91-264 357-05	19						
91-264 358-05	19						
91-266 114-15	9						
91-700 082-15	13, 28						
91-700 364-25	9						
91-700 412-25	13						
91-700 510-15	14, 16						
91-700 592-15	15						
91-700 689-15	16, 20, 24						
91-700 785-15	23, 24, 30, 31						
91-700 961-15	18, 29						
91-700 996-15	19						
91-709 610-71/698	29						
95-665 735-91	36						
95-774 464-05	19						
95-774 466-91	19						
96-711 962-05	14						
99-135 161-85	25						
99-137 001-05	9						
99-137 151-45	19						



1245

1246

Unterklassen-Ausstattung

Subclass parts

Composición de las subclases

零件表

-6/01

Für allgemeine Näharbeiten. For ordinary sewing operations.  
(Standardform des Teilesatzes.) (Standard part set.)

Para trabajos de costura en general.  
(Juego de piezas estándar.)

适用于一般性缝纫工作。  
(套件的标准型式。)

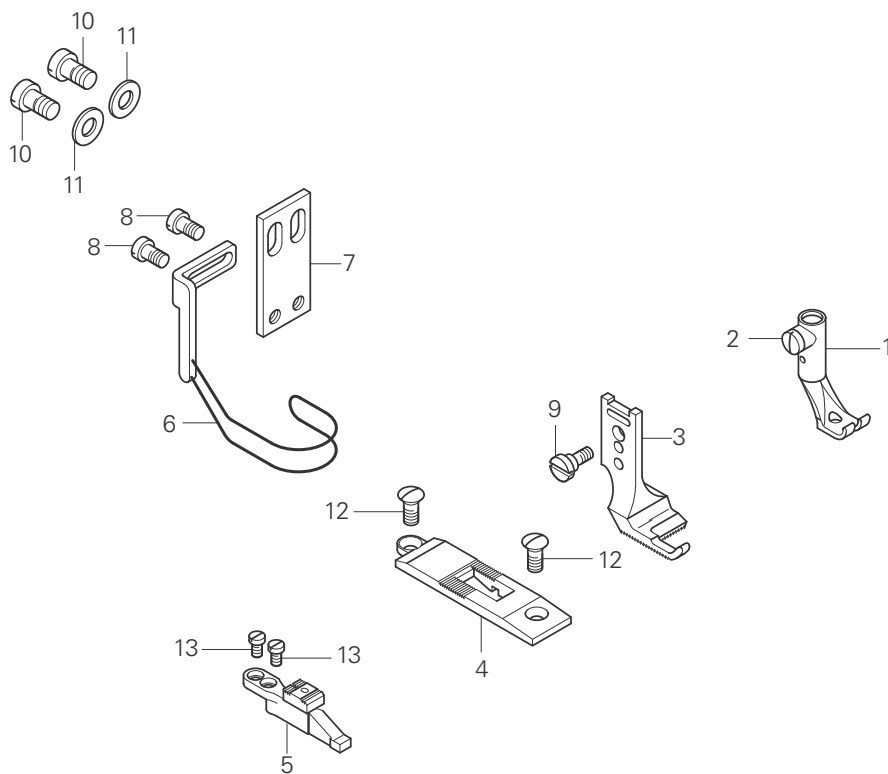

Pos.-Nr. Item No. 序号	Ausführung Model 款式	Stichlänge Stitch length Largo de puntada 针距	Teile-Nr. Part No. 零件号
1 - 8	CN8	8,0	91-201 574-93/001
1 - 2			91-049 269-93/006
2			91-000 085-15
3			91-049 585-04/004
4			91-048 922-04/002
5			91-026 745-04/003
6 - 8			91-057 741-91
6			91-057 742-91

Pos.-Nr. Item No. 序号	Ausführung Model 款式	Stichlänge Stitch length Largo de puntada 针距	Teile-Nr. Part No. 零件号
7			91-057 720-15
8			11-108 171-15
9			91-100 366-15
10			11-108 222-15
11			12-305 144-15
12			91-000 422-25
13			91-000 407-15

-17/01

Arbeitsgang  
 Operation  
 Operación  
 工序

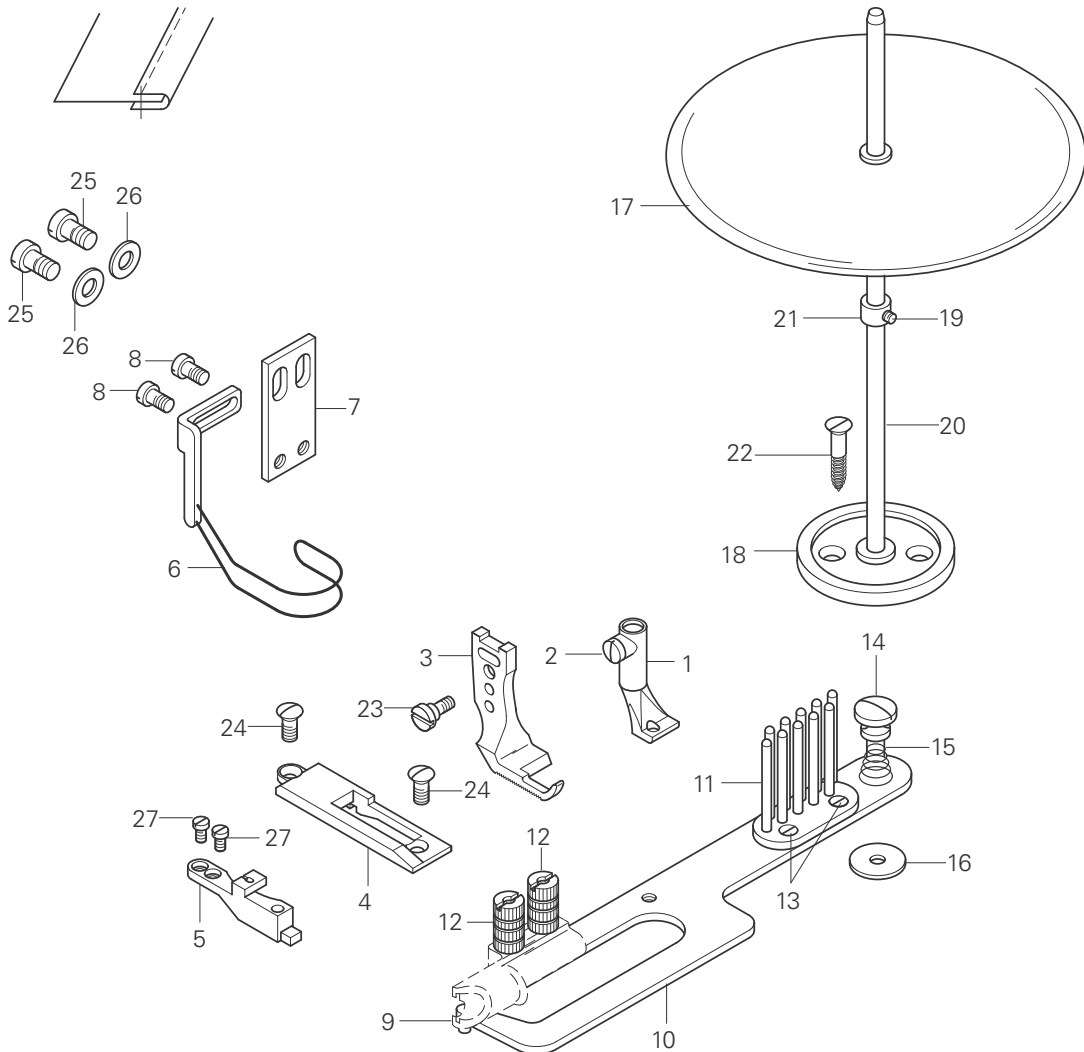

Pos.-Nr. Item No. № de pos. 序号	Ausführung Model Tipo 款式	Stichlänge Stitch length Largo de puntada 针距	Teile-Nr. Part No. № de pieza 零件号	Pos.-Nr. Item No. № de pos. 序号	Ausführung Model Tipo 款式	Stichlänge Stitch length Largo de puntada 针距	Teile-Nr. Part No. № de pieza 零件号
1 - 16	CN8	8,0	91-201 581-93/003	14			91-000 824-25
1 - 2			91-049 819-93/024	15			91-040 624-25
2			91-000 085-15	16			91-028 036-25
3			91-149 227-04/001	17 - 22			91-043 943-70/895
4			91-150 862-04/002	17			91-043 124-71/895
5			91-045 591-04/003	18			91-043 945-75/895
6 - 8			91-057 721-91	19			91-043 947-92
6			91-057 697-91	20			91-043 946-25
7			91-057 720-15	21			91-000 388-15
8			11-108 171-15	22			11-472 250-55
9			5	23			91-100 366-15
10 - 16			91-045 607-90	24			91-000 422-25
10			91-053 752-21	25			11-108 222-15
11			91-044 251-21	26			12-305 144-15
12			91-001 592-25	27			91-000 422-25
13			91-000 380-15				

5 / \* siehe Kapitel 2 Erläuterung der Schlüsselzeichen  
 see chapter 2 Explanation of key markings  
 见第2章标记说明

▲ Weitere Unterklassen und Ausführungen auf Anfrage  
 Further Subclasses and versions on enquiry  
 更多的子机型和款式请咨询

-6/01

Für allgemeine Näharbeiten. For ordinary sewing operations.  
(Standardform des Teilesatzes.) (Standard part set.)

Para trabajos de costura en general.  
(Juego de piezas estándar.)

适用于一般性缝纫工作。  
(套件的标准型式。)

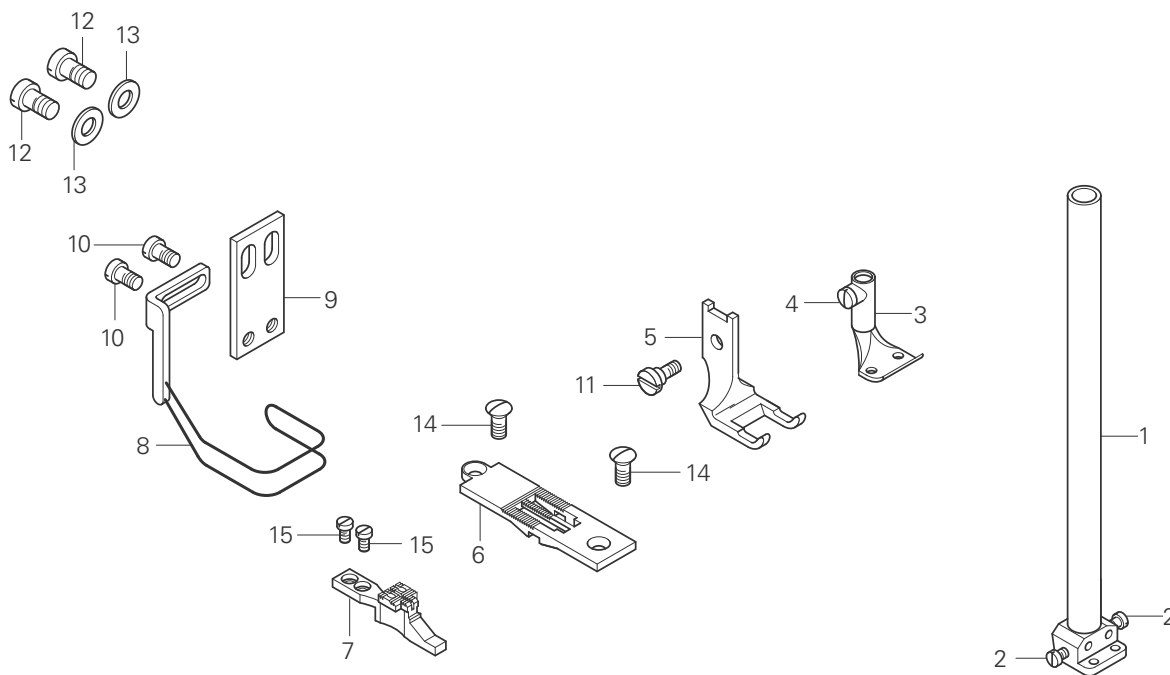

Pos.-Nr. Item No. 序号	Ausführung Model 款式	Stichlänge Stitch length Largo de puntada 针距	Nadelabstand Needle gauge Distancia entre agujas 机针间距	Teile-Nr. Part No. 零件号
1 - 10	CN	6,0	6,4	91-201 111-93/001
	CN	6,0	10,0	91-201 111-93/002
	CN8	8,0	12,0	91-201 114-93/004
1 - 2	CN	6,0	6,4	91-710 749-93/010
	CN	6,0	10,0	91-710 749-93/015
	CN8	8,0	12,0	91-710 749-93/017
2				91-173 664-15
3 - 4	CN	6,0	6,4	91-049 267-93/006
	CN	6,0	10,0	91-049 267-93/010
	CN8	8,0	12,0	91-049 267-93/011
4				91-000 085-15
5	CN	6,0	6,4	91-040 429-04/007
	CN	6,0	10,0	91-040 429-04/010
	CN8	8,0	12,0	91-049 668-04/010
6	CN	6,0	6,4	91-040 434-04/051
	CN	6,0	10,0	91-040 434-04/054
	CN8	8,0	12,0	91-158 601-04/016

Pos.-Nr. Item No. 序号	Ausführung Model 款式	Stichlänge Stitch length Largo de puntada 针距	Nadelabstand Needle gauge Distancia entre agujas 机针间距	Teile-Nr. Part No. 零件号
7	CN	6,0	6,4	91-040 433-04/086
	CN	6,0	10,0	91-040 433-04/093
	CN8	8,0	12,0	91-040 433-04/098
8 - 10	CN	6,0		91-057 722-91
	CN8	8,0		91-057 806-91
8	CN	6,0		91-057 708-91
	CN8	8,0		91-057 807-91
9				91-057 720-15
10				11-108 171-15
11				91-100 366-15
12				11-108 222-15
13				12-305 144-15
14				91-000 422-25
15				91-000 407-15





Mauser Spezial  
Pfaff Industrial (Taicang) Co., Ltd.  
A20 Foreign Industrial Park  
No. 105 East Shanghai Road  
215400 Taicang, Jiangsu, PRC

T: +86 (0)512 5328 3258  
F: +86 (0)512 5328 3242  
[www.mauser-spezial.com](http://www.mauser-spezial.com)  
[info@mauser-spezial.com](mailto:info@mauser-spezial.com)

German Headquarter  
Tribonia Intl. GmbH  
Tanusstraße 5  
65183 Wiesbaden  
Germany

From the library of: Superior Sewing Machine & Supply LLC